

## Designing a Potentiostatic Circuit

### Introduction

In a three-electrode sensor, each electrode has a specific use:

- The **working electrode** responds to the target gas, either oxidising or reducing the gas, creating a current flow that is proportional to the gas concentration. This current must be supplied to the sensor through the counter electrode.
- The **reference electrode** is used by the potentiostatic circuit to maintain a fixed potential at the working electrode. The working electrode potential must be maintained at the same potential as the reference electrode potential for unbiased sensors, or with an offset for sensors that require biasing.
- The **counter electrode** completes the circuit with the working electrode, reducing some chemical species (normally oxygen) if the working electrode is oxidising, or oxidising if the working electrode is reducing the target gas. The potential of the counter electrode is allowed to float, sometimes changing as the gas concentration increases. The potential on the counter electrode is not important, so long as the potentiostat circuit can provide sufficient voltage and current to maintain the working electrode at the same potential as the reference electrode.

Figure 1 is a circuit diagram of a zero bias potentiostat circuit. Refer to this during the discussions below.

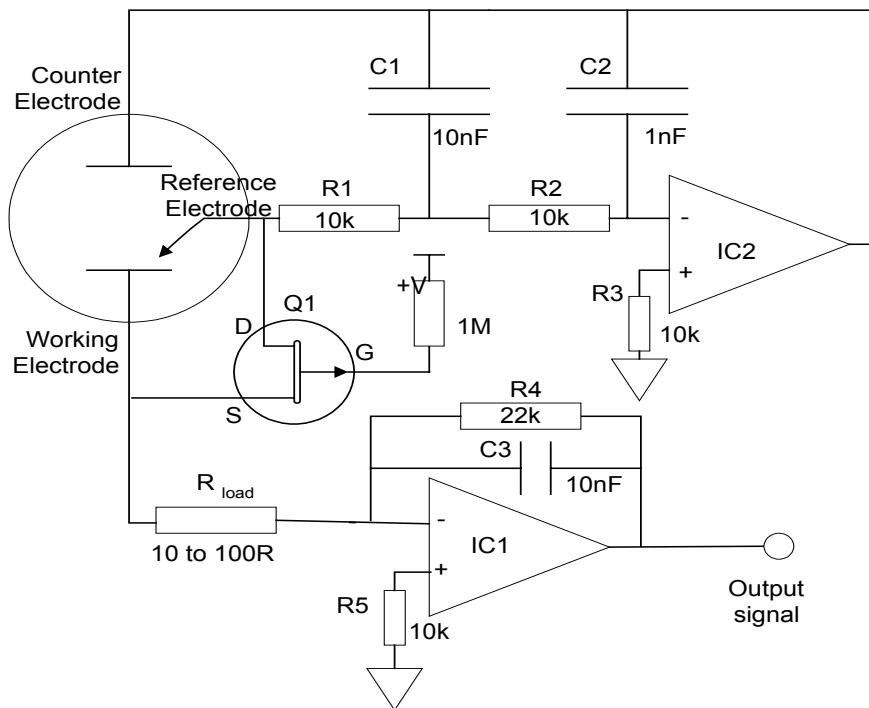

Figure 1 Preferred potentiostat circuit for zero bias toxic gas sensors. ICs require +/-, not single ended power supply.

A typical potentiostat circuit consists of three parts:

1. Control circuit with bias voltage, if required
2. Current measuring circuit
3. Shorting FET to connect the working electrode to the reference electrode when power is off

## Control Circuit

The control op amp (IC2 in figure 1) provides the current to the counter electrode to balance the current required by the working electrode.

The inverting input into IC2 is connected to the reference electrode and must not draw any significant current from the reference electrode. An op amp with an input bias current of less than 5nA is recommended.

When switching on the circuit, the depletion mode JFET (Q1 in Fig 1) goes to a high impedance state and IC2 provides the current to maintain the working electrode at the same potential as the reference electrode. Any offset due to the input offset voltage in IC2 will therefore cause a sudden shift in potential at switch-on. Toxic gas sensors have a large capacitance, so significant currents can flow for small potential shifts, so ensure that your op amp has a low offset voltage, certainly less than 1 mV and preferably less than 100 $\mu$ V; also check the op amp offset voltage at the maximum usage temperature.

Typically, for an oxidisable gas (such as CO) with a platinum reference electrode, the counter electrode will be -300 to -400mV from the ground potential. However, if hydrogen ions rather than oxygen molecules are reduced, then the potential could be as large as -1.05V. Also, reducing gases (such as NO<sub>2</sub> or Chlorine) force the counter electrode to oxidise water, evolving oxygen; in this case the potential relative to the reference electrode is between +600 and +800 mV, depending on the type of reference electrode. Therefore, you must allow IC2 enough voltage swing to drive the counter electrode to the required potential and with sufficient current demanded by the sensor. If the circuit is unable to do this, then extreme non-linearities will occur at higher concentrations. It is best to allow  $\pm 1.1$ V swing on IC2 (plus any imposed bias voltage). This means that for a CO or H<sub>2</sub>S sensor the counter electrode wants to be typically -350 mV below the ground point, so IC2 needs a negative supply. If you are using a single ended low voltage power supply, pay particular attention to the available output swing on the op amp at the required current.

Table 1 below shows the maximum generated steady state current for each type of sensor. At full scale no sensor generates more than 210 $\mu$ A, but allow at least 500 $\mu$ A for a general purpose circuit, although this can be decreased for specific, well tested sensor/ circuit combinations.

**Beware-** when switching the circuit ON in the presence of an electroactive gas or when a new sensor is first connected, the sensor may give a surge current of several mA that may cause IC1 to clamp, depending on the current drive capacity of IC1; it is unlikely that IC1 can maintain the virtual earth on its inverting input with a high feedback resistor during such a high current transient. Always connect the sensor before powering the circuit.

Circuit stability and noise reduction in the control circuit relies on R1, R2, C1 and C2; C2 may not be necessary for certain op amps. If eliminating C2, then C1 may be increased- between 10 and 100 nF. Suggested op amps are OP90 (single op amp) and OP 296 (dual op amp).

## Bias voltage

Normally, Alphasense toxic gas sensors are operated in the zero bias mode; however, certain sensors, such as NO sensors, require a bias voltage: typically  $\pm 150$  or 300mV for an NO sensor. Alternatively, sensor cross-sensitivity to certain gases can be enhanced by adding a bias voltage.

**BEWARE!** performance can also be degraded if you bias incorrectly! Remember that biasing a normally unbiased sensor may damage the sensor and certainly voids the sensor warranty. Consult Alphasense for further advice.

If you wish to inject a bias voltage then also ensure that your bias voltage is stable: changes of even a few mV can affect sensitivity to gases and rapid changes in the bias voltage by only a mV will generate transient effects for up to hours on the sensor output. A simple method of biasing the sensor is shown in figure 2 below. The 10K load resistor to ground can be removed to reduce the current on  $V_{bias}$ .

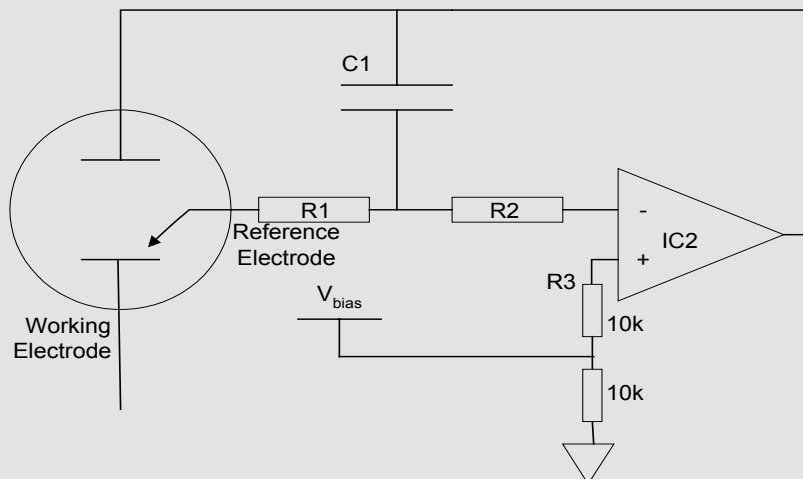

Figure 2. Applying a bias voltage to the control op amp.

Biasing should be maintained when the instrument is switched off - this is normally accomplished by using a button cell battery that remains on at all times. In this case, the input offset of IC2 is not critical, but its drift with temperature etc. must be kept small.

## Current Measuring Circuit

The measuring circuit is a single stage op amp (IC1) in a transimpedance configuration; the sensor current is reflected across R4, generating an output voltage relative to the virtual earth. C3 reduces high frequency noise. It is sometimes desirable to use two opamp stages to give the required output; the first stage should use a low value for R4 to allow the circuit to oppose the sensor current in transient conditions, followed by a second voltage gain stage to give the required output. The input offset voltage of IC1 will add to the sensor bias voltage (as the working electrode will be offset from 0V) so the input offset should be kept low. Remember that the generated current can be either positive or negative: sensors that oxidise at the working electrode (e.g. CO) generate a current into IC2, while reducing working electrodes (e.g. Cl<sub>2</sub> or NO<sub>2</sub>) sink a current. So for the second case, ensure that IC2 has adequate current sinking capability.

The measuring circuit uses a combination of the (load resistor (R<sub>load</sub>) plus internal sensor resistance) and the (internal sensor capacitance) to establish an RC circuit; the selection of R<sub>load</sub> is a compromise between fastest response time (low resistance R<sub>load</sub>) and best noise (high resistance R<sub>load</sub>): this RC circuit affects both the rms noise and the response time: the response time increases linearly with increasing R<sub>load</sub> resistance, while noise decreases rapidly with increasing R<sub>load</sub> resistance. If you need highest resolution, then forfeit fast response time. Likewise, if fast response time is critical, then reduce the resolution of your display or sample the signal faster and average over several readings in software to eliminate jitter. Due to the low impedance nature of the circuit, it is better to use an opamp with low noise current (usually at the expense of noise voltage) to get the best overall noise performance.

As sensor current flows through R<sub>load</sub>, there will be a small change to the sensor bias potential. This has the effect of increasing the sensor settling time as the sensor will require a short time to re-stabilise when gas is applied, but this transient will normally not be seen except at high gas concentrations and high R<sub>load</sub> resistance.

Refer to Table 1 below to calculate the required gain for your measuring circuit. If your detector/instrument does not use the full scale of the sensor, then simply multiply the Sensitivity by your Range to determine the maximum current from the sensor. Since the sensitivity is the typical value, allow 20% more than the typical full scale output into your A/D converter.

Sensor	Full Scale (ppm)	Sensitivity (nA/ppm) (typical)	Full Scale output (µA)	Full Scale output (V)	Calibration point (ppm)
CO-BF, CO-B1, CO-BX	1,000	100	100	1.00	400
CO-AF	1,000	70	70	0.70	400
CO-AX	2,000	65	130	1.30	400
CO-AE	10,000	30	300	3.00	2,000
CO-DF	1,000	40	74	0.74	400
H2S-AH	50	1,200	60	0.60	20
H2S-BH	50	2,000	85	0.85	20
H2S-A1	100	750	75	0.75	20
H2S-B1	200	370	74	0.74	20
H2S-BE	2,000	90	180	1.80	400
H2S-AE	2,000	105	210	2.10	400
H2S-D1	100	140	14	0.14	20
SO2-AF	20	500	10	0.10	20
SO2-BF	100	350	35	0.35	20
SO2-AE	2,000	70	140	1.40	400
NO2-A1	20	-350	8	-0.08	10
NO2-B1	20	-750	22	-0.22	10
NO2-AE	200	-350	70	-0.75	100
NO-A1,-B1	250	400	100	1.00	50
NO-AE	1,000	100	100	1.00	400
Cl2-A1	20	-370	8	-0.07	10
CL2-B1	20	-900	22	0.22	10

Table 1. List of output parameters and calibration point for Alphasense toxic gas sensors.

## Shorting FET

It is normal practice to add a shorting FET for unbiased sensors so that the reference and working electrodes are shorted together (with a residual resistance of a few tens of ohms) when power is removed from the circuit. This ensures that the working electrode is maintained at the same potential as the reference electrode when the circuit is switched off. The shorting FET is normally open circuit as long as power is applied. This “zero bias” state ensures that when you switch the circuit back on, the sensor is ready immediately. If you do not use a shorting FET and leave the sensor open circuit when the circuit is off, the toxic gas sensor will take a few hours to stabilise when next switched on.

If you are supplying a bias voltage through IC2, then when you switch off the circuit, the sensor will be zero biased and hence when you reapply a bias voltage it will take a significant time (up to several hours) for the sensor to re-establish equilibrium. It is recommended that, for biased circuits, the bias voltage be maintained on at all times and the shorting FET not used. This will not affect the operating life of the sensor.

The JFET (Q1) should be a p-type FET. Recommended FET types include surface mount or TO-92 packages as per Table 2 below.

Manufacturer	Product Code	Type
Siliconix	SST177	Surface Mount
Siliconix	J175	TO-92
Siliconix	J176	TO-92
Siliconix	J177	TO-92
Fairchild	J175	TO-92

Table 2. Recommended p-FETs for short circuiting reference and working electrodes when the potentiostat circuit is off.

## Noise, RFI/EMI Screening

Ideally, the measuring and controlling op amps in a potentiostat are fitted directly underneath the sensor to keep the shortest leads because of the low impedance and low sensor currents. Alphasense Application Note AAN 103 gives further advice on reducing noise and improving RFI/EMI screening.

## Sensor Calibration

Note that toxic gas sensor sensitivities are variable, typically  $\pm 15\%$ . So you must calibrate in software to correct for sensor-to-sensor sensitivity variations. Alphasense maintains a database of the sensitivity of every sensor tested at Alphasense, but remember that sensitivity will drift downwards with time, typically 0.5% to 2% per month, depending on the sensor type, relative humidity and gas concentration/ temperature conditions. See Application Note AAN 108 for more information.

It is also normal to correct for temperature dependence of the sensitivity; zero current is not normally temperature corrected, but for measurements requiring high accuracy at low concentrations, contact Alphasense for advice.