



CO-D4 Carbon Monoxide Sensor Miniature Size



PATENTED and PATENT
PENDING

Figure 1 CO-D4 Schematic Diagram

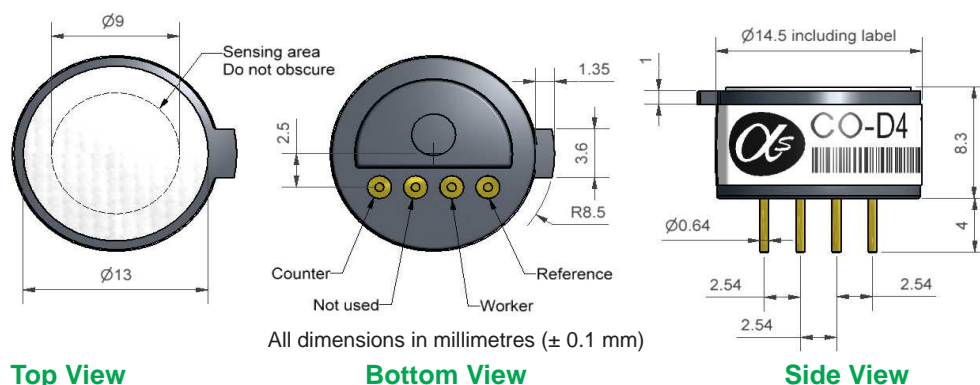

All dimensions in millimetres (± 0.1 mm)
(A three pin version is available on request, coded CO-DF)

PERFORMANCE	Sensitivity		nA/ppm in 400ppm CO	30 to 55
		Response time	t_{90} (s) from zero to 400ppm CO % 22°C	
	Zero current	ppm equivalent in zero air		< ± 3
	Resolution	RMS noise (ppm equivalent)		< 1.5
	Range	ppm limit of performance warranty		1,000
	Linearity	ppm CO error at full scale, linear at zero and 400ppm CO		± 40
	Overgas limit	maximum ppm for stable response to gas pulse		2,000

LIFETIME	Zero drift	ppm equivalent change/year in lab air	< 0.5
	Sensitivity drift	% change/year in lab air, monthly test	< 6
	Operating life	months until 80% original signal (24 month warranted)	> 18

ENVIRONMENTAL	Sensitivity @ -20°C	% (output @ -20°C/output @ 20°C) @ 400ppm CO	45 to 70
	Sensitivity @ 50°C	% (output @ 50°C/output @ 20°C) @ 400ppm CO	105 to 125
	Zero @ -20°C	ppm equivalent change from 20°C	< ± 2
	Zero @ 50°C	ppm equivalent change from 20°C	< ± 4

CROSS SENSITIVITY	Filter capacity	ppm-hrs	H ₂ S	20,000
	H ₂ S sensitivity	% measured gas @ 20ppm	H ₂ S	< 0.1
	NO ₂ sensitivity	% measured gas @ 10ppm	NO ₂	< 6
	Cl ₂ sensitivity	% measured gas @ 10ppm	Cl ₂	< 0.1
	NO sensitivity	% measured gas @ 50ppm	NO	< 60
	SO ₂ sensitivity	% measured gas @ 20ppm	SO ₂	< 0.1
	H ₂ sensitivity	% measured gas @ 400ppm	H ₂	< 40
	C ₂ H ₄ sensitivity	% measured gas @ 400ppm	C ₂ H ₄	< 110
	NH ₃ sensitivity	% measured gas @ 20ppm	NH ₃	< 0.1

KEY SPECIFICATIONS	Temperature range	°C	-20 to 50
	Pressure range	kPa	80 to 120
	Humidity range	%rh (see note below)	15 to 90
	Storage period	months @ 3 to 20°C (stored in sealed pot)	6
	Load resistor	Ω (recommended)	10 to 47
	Weight	g	< 2

Note: Above 85% rh and 40°C a maximum continuous exposure period of 10 days is warranted. Where such exposure occurs the sensor will recover normal electrolyte volumes when allowed to rest at lower %rh and temperature levels for several days.



At the end of the product's life, do not dispose of any electronic sensor, component or instrument in the domestic waste, but contact the instrument manufacturer, Alphasense or its distributor for disposal instructions.

NOTE: all sensors are tested at ambient environmental conditions, with 10 ohm load resistor, unless otherwise stated. As applications of use are outside our control, the information provided is given without legal responsibility. Customers should test under their own conditions, to ensure that the sensors are suitable for their own requirements.



CO-D4 Performance Data

Technical Specification

Figure 2 Sensitivity Temperature Dependence

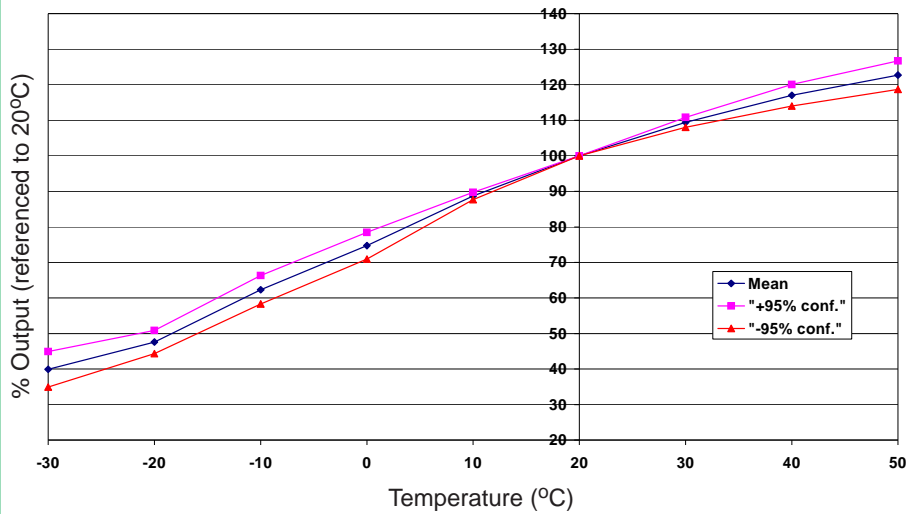

Figure 2 shows the variation in sensitivity caused by changes in temperature. Repeatable temperature dependence at elevated temperatures allows more accurate temperature compensation.

This data is taken from a typical batch of sensors. The mean and $\pm 95\%$ confidence intervals are shown.

Figure 3 Zero Temperature Dependence

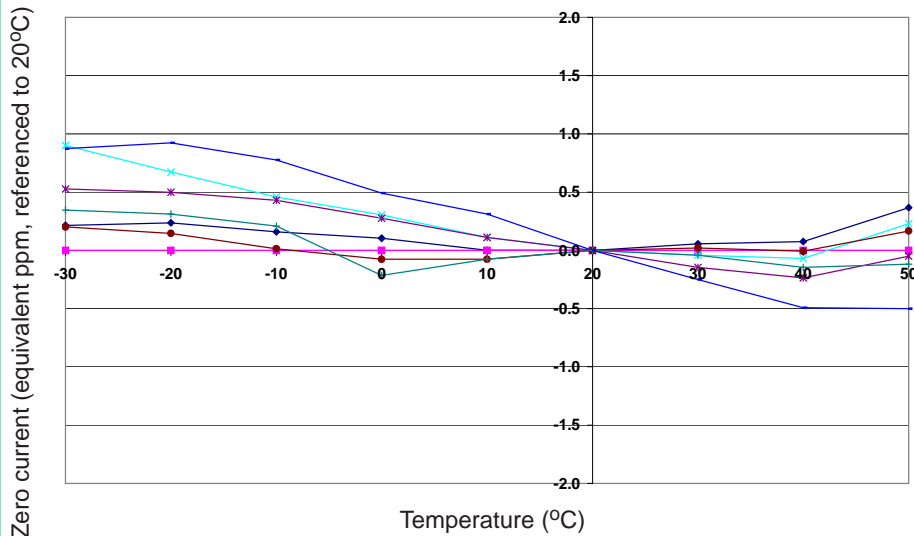

Figure 3 shows the variation in zero output caused by changes in temperature, expressed as ppm gas equivalent, referenced to zero at 20°C.

This data is taken from a typical batch of sensors.

Figure 4 Response to 4,000ppm CO

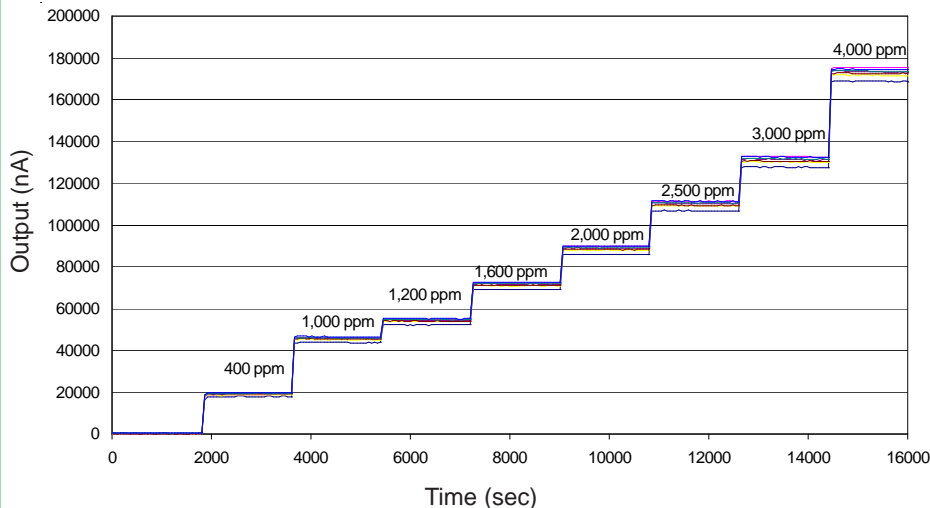

Figure 4 shows sensor output for increasing concentrations of CO, up to twice the specified overgas concentration. Data shown is eight sensors taken from a typical production batch.

This stepped overgas test shows the robustness of the sensor with fast response and straight plateaus at each step.

For further information on the performance of this sensor, on other sensors in the range or any other subject, please contact Alphasense Ltd. or visit our web site at www.alphasense.com.

In the interest of continued product improvement, we reserve the right to change design features and specifications without prior notification. The data contained in this document is for guidance only. Alphasense Ltd accepts no liability for any consequential losses, injury or damage resulting from the use of this document or the information contained within. ©ALPHASENSE LTD) Doc. Ref. COD4/DEC20