

NDIR: Electronic Interface and Signal Extraction for Thermopile Sensors

1. Introduction

Alphasense IRC-AT (carbon dioxide), and IRM-AT (methane) thermopile, NDIR sensors consist of an infrared source, an optical cavity, a dual channel thermopile detector and an internal thermistor. This application note details the electronic interface necessary to obtain useful signals from the sensors.

2. Source Drive

The infrared source may be switched at a low frequency with a 50% duty cycle. A switching frequency of 1 to 3 Hz, derived from a crystal oscillator source is recommended. The source should be driven from a constant voltage source and care should be taken to ensure the supply does not contain low frequency ripple that would otherwise modulate the output. The nominal resistance of the source is approximately 9 to 10 Ohms at ambient temperatures and will draw approximately 50 to 60 mA at 5 V. The average current will be half of this figure when driven at 50% duty cycle.

The circuit shown in Figure 1 uses an n-channel MOSFET to switch the low side of the source with the high side connected to a stable supply (typically +5 VDC). The MOSFET should have a low RDS ON resistance to minimise its voltage drop. If the high side is driven and the low side is grounded, care must be taken to keep the detector ground separate from the source ground to avoid pickup due to the source current circulating in the detector ground. The source is galvanically isolated from the detectors and thermistor in the sensor.

3. Detector Signal Amplification and Filtering

A suitable circuit for driving the sensor is shown in Figure 1. There are two detector channels inside the thermopile detector. The active detector will respond to changes in target gas levels whereas the reference detector will be substantially unaffected. However both detectors will be affected by ambient temperature and the IR source luminosity and appropriate processing of both channels will minimise these unwanted effects (see Application Note AAN 201).

The raw active and reference signals are composed of a DC offset voltage (typically 9.0 mV) with a small amplitude (1 to 7 mV peak to peak) superimposed response. This signal alternates in phase with the source drive voltage (Figure 2a). The alternating signal can be filtered and amplified (Figure 2b) in order to obtain a measure of the peak-to-peak amplitude of this oscillating component. The circuit shown in Figure 1 will give an amplification of 759 therefore the output from the active or reference channel could vary between 1.5 and 5.3 V peak-to-peak (bipolar around 0 V). The specific gain should be adjusted to make use of the full range of the ADC used. Increasing the lamp frequency will decrease the amplitude while a decrease in frequency will increase the amplitude. For unipolar ADCs, C1, C2, R1, R3, R4, R7, R9 & R10 could be connected to a mid rail supply that is well decoupled to AGND. This peak-to-peak amplitude is used to determine the gas concentration (see Application Note AAN 201).

The source and detectors have a significant response time (hence the reason for the relatively low pulse frequency). The amplification stage should include a low pass response with a roll off of about four times the switching frequency to reduce high frequency noise, and a high pass (AC coupling) stage of approx. 0.1 Hz to remove the DC bias from the detectors.

Figure 1: Circuit suitable for driving the lamp and amplifying the signal from a thermopile IRC-AT sensor

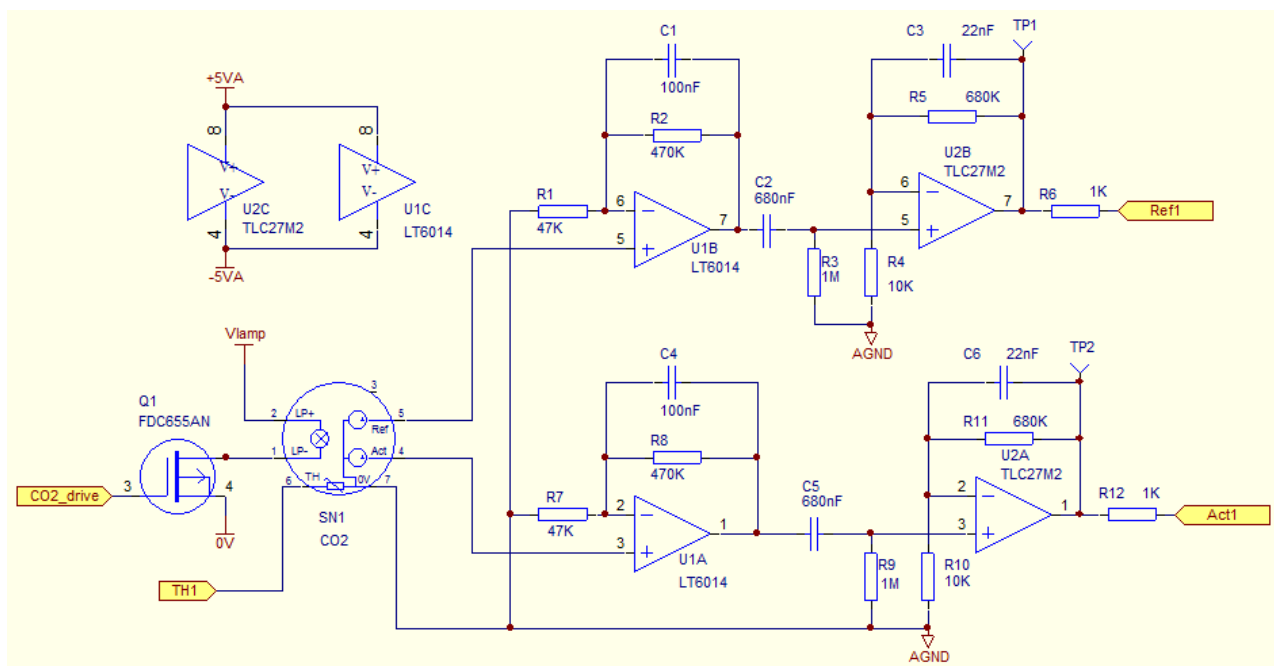
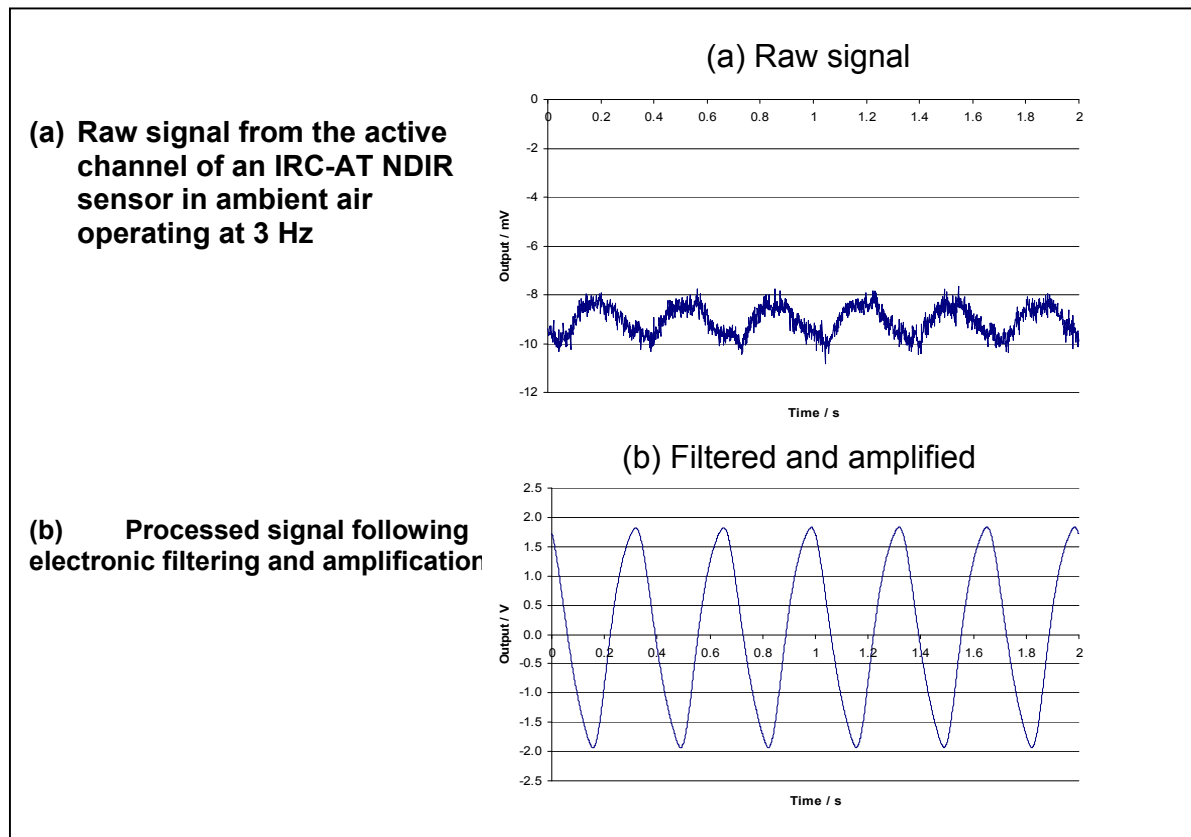

Figure 2: Raw and amplified signals from a thermopile sensor



4. Thermistor Output

The sensor includes an integral thermistor to monitor the internal temperature. Internally, the thermistor is connected to AGND. The thermistor output should be connected in series with a known resistor and reference voltage. The potential at the junction between the resistors can then be used to determine the thermistor resistance and the temperature from table 1 below.

Temp (°C)	R (Ω) +/- 5% β = 3940 K
-30	1654899
-25	1234476
-20	928719
-15	704455
-10	538476
-5	414606
0	321668
5	251388
10	197771
15	156591
20	124759
25	100000
30	80625
35	65379
40	53305
45	43682
50	35975
55	29768
60	24748

Table 1: Thermistor resistance table

Note that with a 5 V supply to the sensor, the sensor will operate up to about 5 °C warmer than the ambient temperature due to heat generated by the IR light source. Therefore you should monitor the sensor temperature for temperature compensation and not the ambient temperature.

The following equation can also be used to estimate the temperature from the determined resistance given R_{25} and Beta from Table 1 above.

$$T(^{\circ}C) = \frac{\beta}{\ln \left[\frac{R}{R_{25} \cdot \exp\left(-\beta/298.15\right)} \right]} - 273.15$$