

## SO2-BF/SO2-BF+ Sulfur Dioxide Sensor

The SO2-BF sensor is a PPM sensor that is designed for a broad variety of applications and instrumentation including portable gas detectors and fixed gas detection systems for industrial safety, environmental air quality and process control. This product is available in our standard format (SO2-BF) and with our patented Integrated Smart Technology (SO2-BF+) that has an IST board with a memory chip and temperature sensor integrated in the sensor. The + sensors store specific calibration, specification, and identification data on every sensor allowing plug and play operation. The on-board temperature sensor improves the accuracy and simplicity of temperature compensation algorithms.

### SO2-BF Sulfur Dioxide Sensor – 3-Electrode

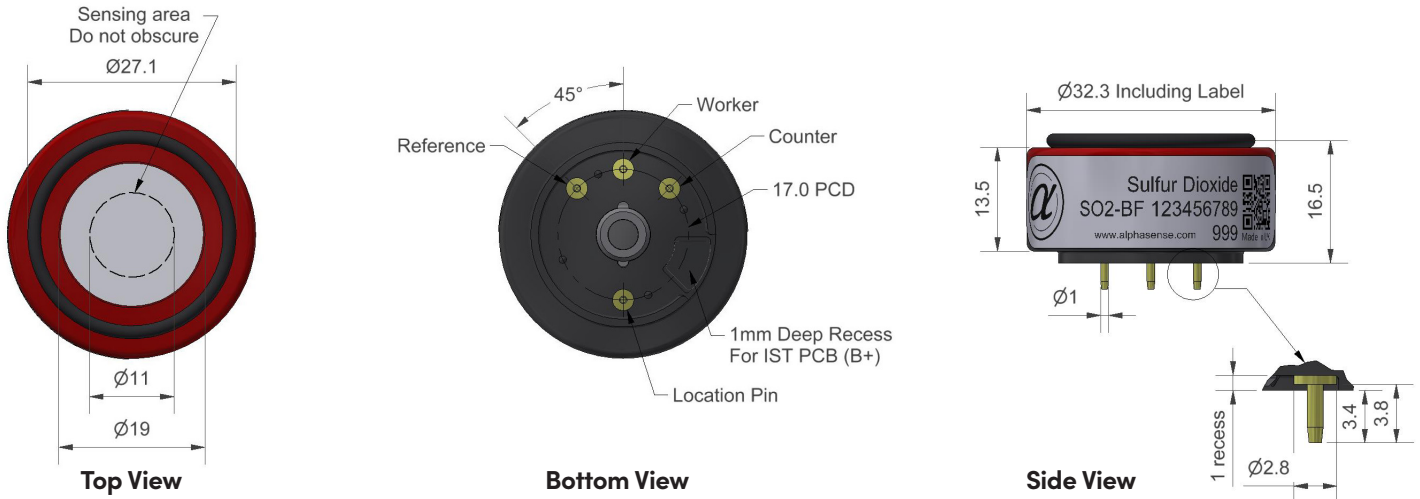

### SO2-BF+ Sulfur Dioxide Sensor – 3-Electrode (with Integrated Smart Technology)

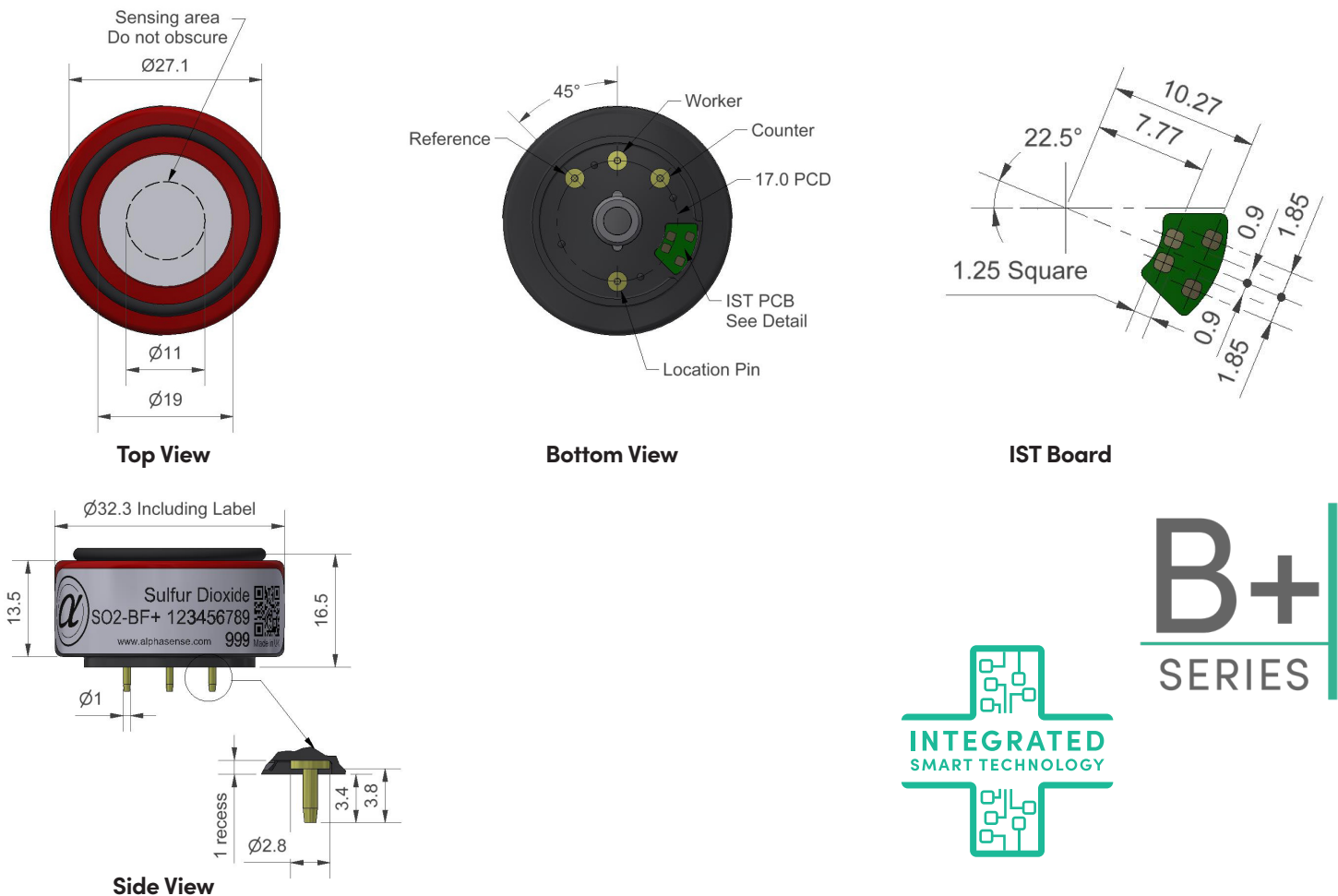

Dimensions are in millimetres (± 0.15 mm).

## Sensor Data

<b>Performance</b>	Sensitivity	nA/ppm in 20ppm SO <sub>2</sub>	300 to 480
	Response time	t <sub>90</sub> (s) from zero to 20ppm SO <sub>2</sub>	< 40
	Zero current	ppm equivalent in zero air	< ±0.5
	Resolution	RMS noise (ppm equivalent)	< 0.1
	Range	ppm limit of performance warranty	100
	Linearity	ppm error at full scale, linear at zero and 20ppm SO <sub>2</sub>	< ±2
	Overgas limit	maximum ppm for stable response to gas pulse	1000
<b>Lifetime</b>	Zero drift	ppm equivalent change/year in lab air	< 0.1
	Sensitivity drift	% change/year in lab air, monthly test	< 4
	Operating life	months until 80% original signal (24 month warranted)	> 24
<b>Environmental</b>	Sensitivity @ -20°C	% (output @ -20°C/output @ 20°C) @ 20ppm	78 to 90
	Sensitivity @ 50°C	% (output @ 50°C/output @ 20°C) @ 10ppm	100 to 120
	Zero @ -20°C	ppm equivalent change from 20°C	< 0 to 1
	Zero @ 50°C	ppm equivalent change from 20°C	< 0 to 2
<b>Cross sensitivity</b>	Filter capacity	ppm-hrs H <sub>2</sub> S	450
	H <sub>2</sub> S sensitivity	% measured gas @ 20ppm H <sub>2</sub> S	< 2
	NO <sub>2</sub> sensitivity	% measured gas @ 10ppm NO <sub>2</sub>	< -120
	Cl <sub>2</sub> sensitivity	% measured gas @ 10ppm Cl <sub>2</sub>	< -50
	NO sensitivity	% measured gas @ 50ppm NO	< -10
	CO sensitivity	% measured gas @ 400ppm CO	< 1.5
	H <sub>2</sub> sensitivity	% measured gas @ 400ppm H <sub>2</sub>	< 0.5
	C <sub>2</sub> H <sub>4</sub> sensitivity	% measured gas @ 400ppm C <sub>2</sub> H <sub>4</sub>	< 50
NH <sub>3</sub> sensitivity	% measured gas @ 20ppm NH <sub>3</sub>	< 0.1	
<b>Key specifications</b>	Temperature range	°C	-30 to 50
	Pressure range	kPa	80 to 120
	Humidity range	% rh continuous	15 to 90
	Storage period	months @ 3 to 20°C (stored in sealed pot)	6
	Load resistor	Ω (recommended)	10 to 47
	Weight	g	< 13

**Figure 1 Sensitivity Temperature Dependence**

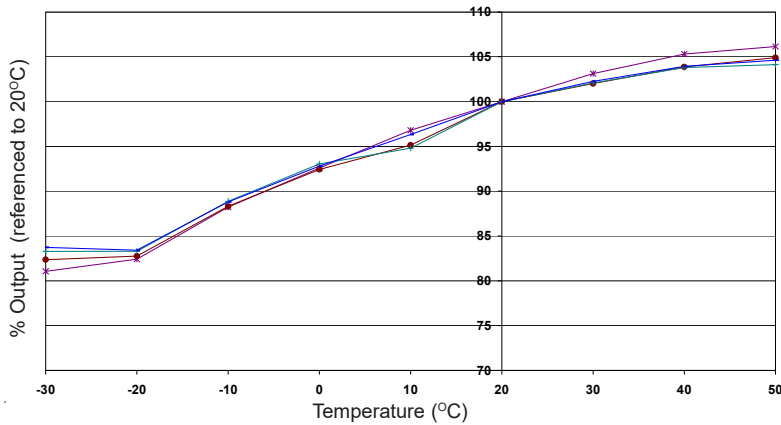

Figure 1 shows the variation in sensitivity caused by changes in temperature.  
This data is taken from a typical batch of sensors.

**Figure 2 Zero Temperature Dependence**

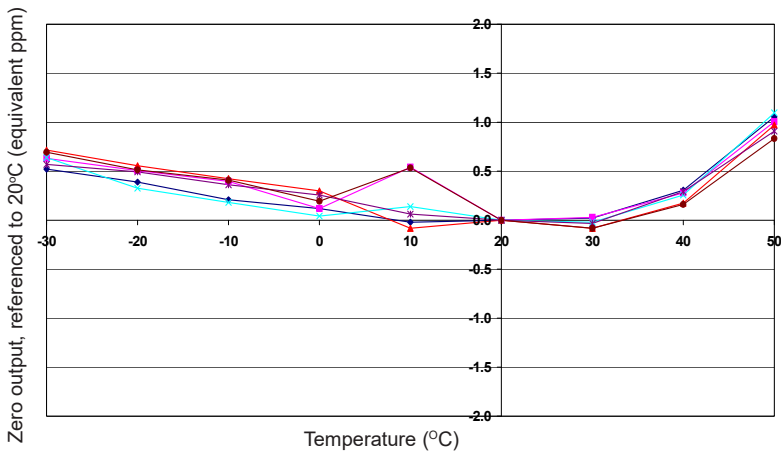

Figure 2 shows the variation in zero output caused by changes in temperature, expressed as ppm gas equivalent, referenced to zero at 20°C.  
This data is taken from a typical batch of sensors.

**Figure 3 Response to 1000 ppm SO<sub>2</sub>**

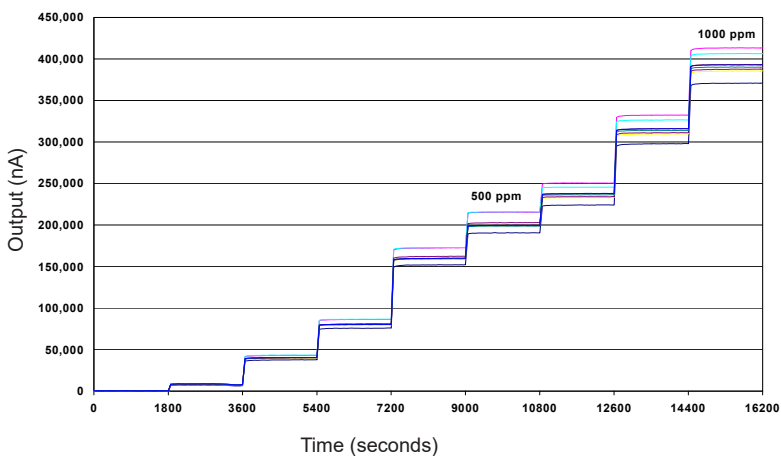

Figure 4 shows the response of the SO<sub>2</sub>-BF up to 1000ppm SO<sub>2</sub>.  
This data is taken from a typical batch of sensors.  
The output remains linear and stable up to 1000ppm SO<sub>2</sub>. Sensors recover from overgas without change to their performance.

## IST Board Data

<b>Interface</b>	Communication Bus	Compatible with the 400 kHz I <sup>2</sup> C protocol
	Max. Bus Speed	Up to 1 MHz
	Input Logic Levels	High (Recessive) < 2.3 V   Low (Dominant) < 0.2 V
	Absolute Max. Input Signal	3.6 V

<b>Electrical</b>	Supply Voltage Range	1.7 V to 3.6 V
	Supply current – Stand-By	< 5 µA
	Supply current – Operating	< 0.15 mA (temperature reading only) < 2.15 mA (temperature reading + memory reading/writing)
	Power Supply Conditioning	Built-In 100 nF decoupling capacitor
	ESD Protection	4 kV (human body model) – Enhanced ESD / Latch-Up protection
	Bus Pins Input Capacitance	15 pF max.

<b>Performance</b>	Operational Temperature	-40 °C to +85 °C
	Temperature Sensor Accuracy	±1°C (-0°C to +70°C)
	Memory Data Retention	> 200 years
	Memory Write Cycles	> 4,000,000

<b>Data &amp; Communication</b>	Memory IC & I2C Address	M24128X-FCU   Device Address: R – 0xA0 / W – 0xA1
	Temperature IC & I2C Address	MAX31875R0TZS+T   Device Address: R – 0x90 / W – 0x91
	Product Data Start Address	0x0900
	Calibration Data Start Address	0x0B00
	User Data Area	0x0D00 – 0x18FF (3,072 Bytes)
	CRC Polynomial	0x 01 04C1 1DB7
	Digital Signature Algorithm	SHA-256

### Factory-populated data

<b>Product Data</b>
Data Format Version
Customer (OEM) ID
Product ID
Type of Sensor / Target Gas
Sensor Serial Number
End of Storage Period Date
Sensor Replacement Date
Product Data Checksum
Alphasense Digital Signature
Customer Digital Signature

<b>Calibration</b>
Calibration Data Units
Zero (clean dry air) Output
Calibration Span
Calibration Output
Sensitivity
Calibration Date
Calibration Data Checksum
Calibration Data Signature

<b>Sensor Specification</b>
Over-gas limit
Concentration Range
Temperature Range Low
Temperature Range High
Humidity Range Low
Humidity Range High
Pressure Range Low
Pressure Range High
Specification Checksum

### 15,000+ locations

<b>Customer Specific</b>
Custom Parameters
Re-Calibration Due Date
Operational Limits:
Low   High   STEL   TWA
Next Bump Test Due Date
User Data Area

\*Note: Above 85% rh and 40°C a maximum continuous exposure period of 10 days is warranted. Where such exposure occurs the sensor will recover normal electrolyte volumes when allowed to rest at lower % rh and temperature levels for several days.

At the end of the product's life, do not dispose of any electronic sensor, component or instrument in the domestic waste, but contact the instrument manufacturer, Alphasense or its distributor for disposal instructions. NOTE: All sensors are tested at ambient environmental conditions, with 10 ohm load resistor, unless otherwise stated. As applications of use are outside our control, the information provided is given without legal responsibility. Customers should test under their own conditions, to ensure that the sensors are suitable for their own requirements.

In the interest of continued product improvement, we reserve the right to change design features and specifications without prior notification. The data contained in this document is for guidance only. Alphasense Ltd accepts no liability for any consequential losses, injury or damage resulting from the use of this document or the information contained within. (©ALPHASENSE LTD) Doc. Ref. SO2-BF/FEB24