



SO2-BF Sulfur Dioxide Sensor



PATENTED

Figure 1 SO2-BF Schematic Diagram

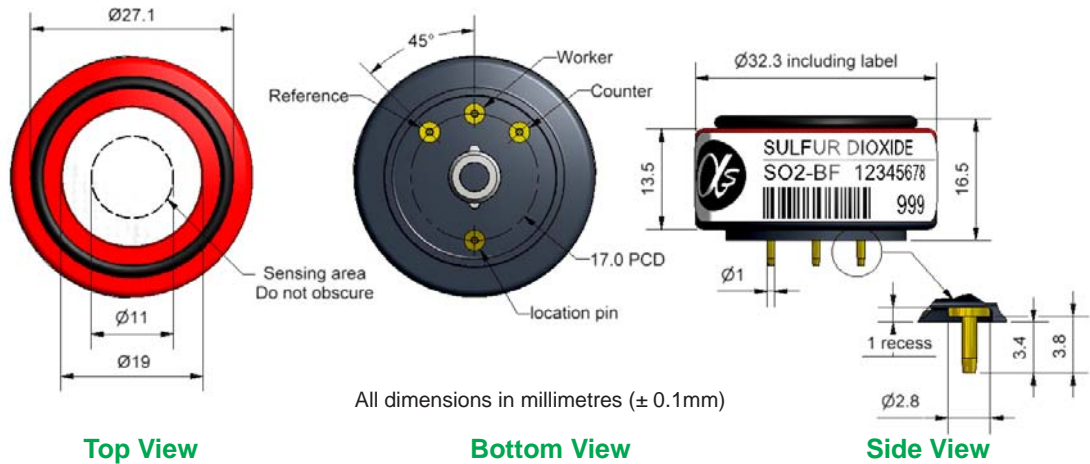

Technical Specification

PERFORMANCE	Sensitivity	nA/ppm in 20ppm SO ₂	300 to 440
	Response time	t ₉₀ (s) from zero to 20ppm SO ₂	< 30
	Zero current	ppm equivalent in zero air	< ± 0.5
	Resolution	RMS noise (ppm equivalent)	< 0.1
	Range	ppm limit of performance warranty	100
	Linearity	ppm error at full scale, linear at zero and 20ppm SO ₂	< ± 2
	Overgas limit	maximum ppm for stable response to gas pulse	500
LIFETIME	Zero drift	ppm equivalent change/year in lab air	< 0.1
	Sensitivity drift	% change/year in lab air, monthly test	< 4
	Operating life	months until 80% original signal (24 month warranted)	> 24
ENVIRONMENTAL	Sensitivity @ -20°C	% (output @ -20°C/output @ 20°C) @ 20ppm	78 to 90
	Sensitivity @ 50°C	% (output @ 50°C/output @ 20°C) @ 20ppm	100 to 107
	Zero @ -20°C	ppm equivalent change from 20°C	< ± 0.4
	Zero @ 50°C	ppm equivalent change from 20°C	< ± 3
CROSS SENSITIVITY	Filter capacity	ppm-hrs	450
	H ₂ S sensitivity	% measured gas @ 20ppm	< 0.1
	NO ₂ sensitivity	% measured gas @ 10ppm	< -120
	Cl ₂ sensitivity	% measured gas @ 10ppm	< -50
	NO sensitivity	% measured gas @ 50ppm	< -3
	CO sensitivity	% measured gas @ 400ppm	< 1
	H ₂ sensitivity	% measured gas @ 400ppm	< 0.1
	C ₂ H ₄ sensitivity	% measured gas @ 400ppm	< 40
	NH ₃ sensitivity	% measured gas @ 20ppm	< 0.1
KEY SPECIFICATIONS	Temperature range	°C	-30 to 50
	Pressure range	kPa	80 to 120
	Humidity range	% rh continuous (see note below)	15 to 90
	Storage period	months @ 3 to 20°C (stored in sealed pot)	6
	Load Resistor	Ω (recommended)	10 to 47
	Weight	g	< 13

Note: Above 85% rh and 40°C a maximum continuous exposure period of 10 days is warranted. Where such exposure occurs the sensor will recover normal electrolyte volumes when allowed to rest at lower % rh and temperature levels for several days.



At the end of the product's life, do not dispose of any electronic sensor, component or instrument in the domestic waste, but contact the instrument manufacturer, Alphasense or its distributor for disposal instructions.

NOTE: all sensors tested and stored at ambient environments unless otherwise stated. As applications of use are outside our control, the information provided is given without legal responsibility. Customers should test under their own conditions, to ensure that the sensors are suitable for their own requirements.



SO2-BF Performance Data



Technical Specification

Figure 2 Sensitivity Temperature Dependence

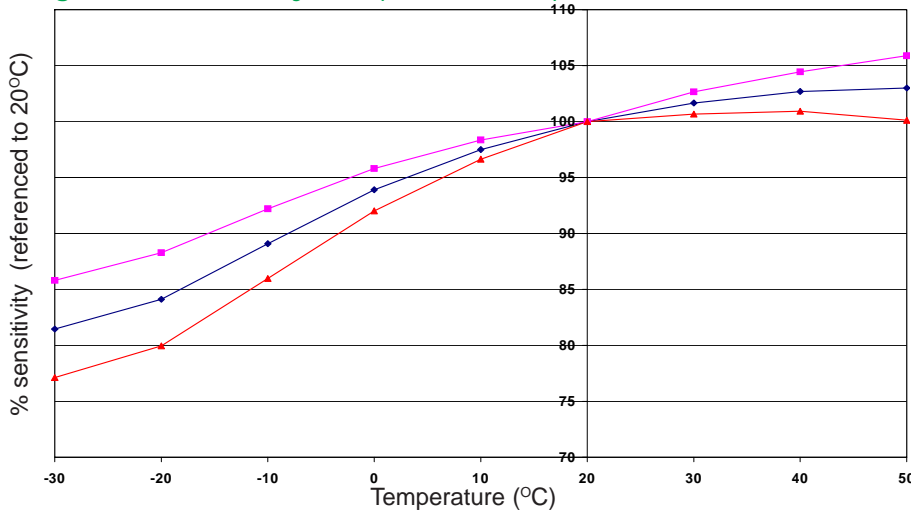

Figure 2 shows the variation in sensitivity caused by changes in temperature.

This data is taken from a typical batch of sensors. The mean and $\pm 95\%$ confidence intervals are shown.

Figure 3 Zero Temperature Dependence

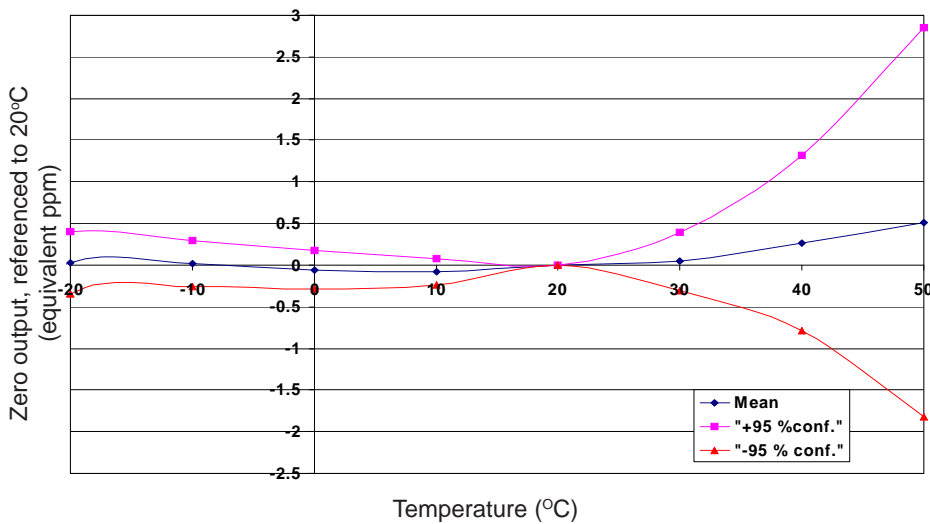

Figure 3 shows the variation in zero output caused by changes in temperature expressed as ppm gas equivalent.

This data is taken from a typical batch of sensors. The mean and $\pm 95\%$ confidence intervals are shown.

Figure 4 Response to 20ppm SO₂

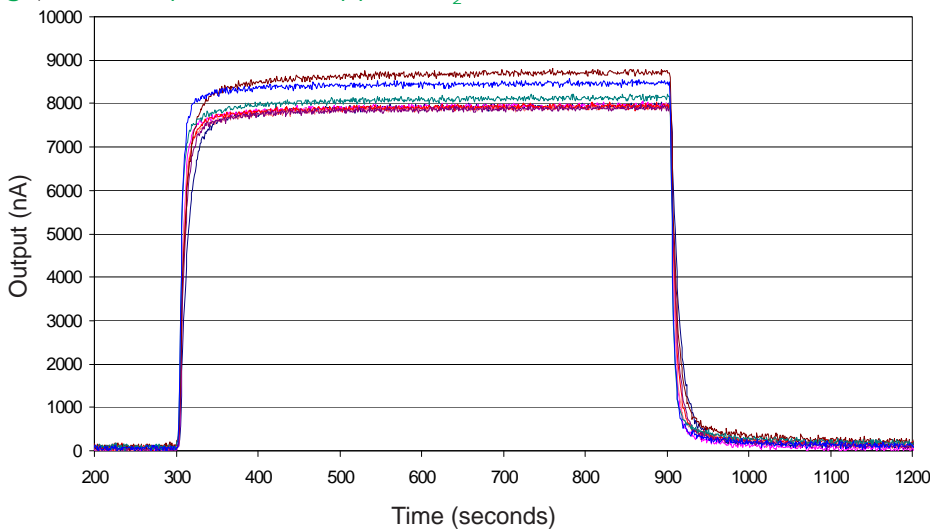

Figure 4 shows the response to 20ppm SO₂.

This data is taken from a typical batch of sensors. The t_{90} response for the SO₂-BF sensor is less than 30 seconds.

For further information on the performance of this sensor, on other sensors in the range or any other subject, please contact Alphasense Ltd. For application notes visit "www.alphasense.com".

In the interest of continued product improvement, we reserve the right to change design features and specifications without prior notification. The data contained in this document is for guidance only. Alphasense Ltd accepts no liability for any consequential losses, injury or damage resulting from the use of this document or the information contained within (©ALPHASENSE LTD) Doc. Ref. SO2BF/MAR11