

AAN 303-04**PID Intrinsic Safety**

This Application Note details design rules and lists IS ratings for the PID-A1. The PID-AH, although built to the same IS specification as the PID-A1, is normally provided with a non-IS label, since very low VOC concentrations measured by the PID-AH are almost always with equipment which is not IS approved.

Supply voltage and zone isolation

It is important in all intrinsically safe circuits to minimise the voltage across power supply rails and the consequential current flowing through them. Select your supply voltage carefully: a higher applied voltage requires a higher current; but this is balanced against expected lamp life- a higher supply voltage gives longer lamp life because a higher strike voltage can be applied to an old lamp to continue its operation.

LEL sensors take considerable current and are often zoned by a separate 125 mA fuse. Depending upon the current drawn by the monitoring electronic circuits, the PID may either share the same zoned 125 mA fuse or the electronics can be located in another zone whose power is supplied by another fuse.

If two zones are required, then very low current signals may be passed between the two zones by isolating resistors to limit any possible high current sharing between the two zones and thus maintain separate zone integrity.

Maximum temperature

The PID-A1 and PID-AH were designed to have minimum response change over their full temperature range, and because performance of potting compounds changes with temperature, there is no potting compound in the PID. However this meant serious design considerations were imposed on the PID-A1 for its T4 temperature rating, due to the lack of internal space for components capable of operating at the 55°C T4 classification (at 1.1 W rating). However, if higher temperature is required then limit the power supplied as shown in the Hazardous Locations Approvals box.

The PID-A1 may be plugged directly into an LEL sensor PCB position, whose power is supplied by an external 125 mA fuse for a T4 rating in an ambient temperature of up to 55°C. The PID-A1 is not rated above 55°C as the internal zener diodes would exceed their internal temperature rise based upon the 3W zeners' current rating at the maximum ambient temperature of about 55°C when tested at the fused clamped current.

Both the PID-A1 and PID-AH can be used up to 65°C in a non-IS gas detector.

Summary for use of the PID-A1 in IS applications

1. External supply surge current must be limited to 3.3 A under fault conditions.
2. The PID-A1 requires a 125mA fuse in the supply line.
3. Take note of the various maximum supply voltages that may become connected to any of the pins under fault conditions.
4. Take note of the power limits of the various pins under fault conditions.
5. The capacitance is low and should not cause problems at these voltages.
6. If processing electronics are located in another zone, then barrier/ segregation resistors are required.
7. Competent third party assessment is required on the final product.

Equivalent Intrinsic Safe Circuit

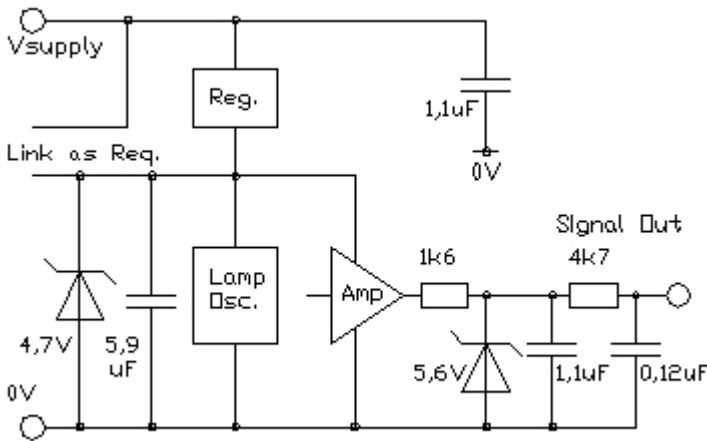

Possible Intrinsically Safe Installations

Basic Intrinsically Safe operation

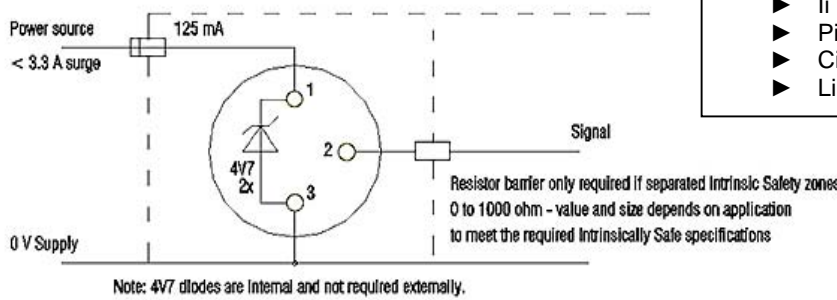

To minimise signal noise

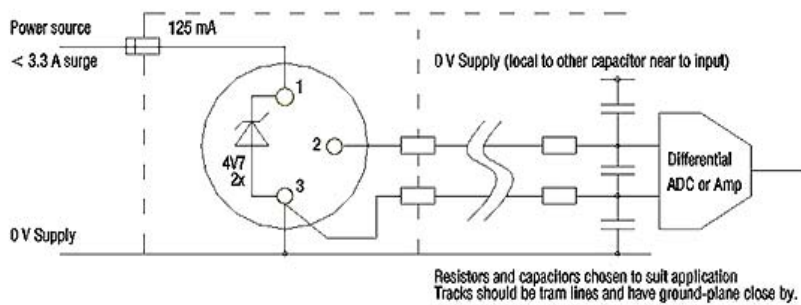

Output range

- Signal from 50mV to Positive rail voltage (-100mV)
- Signal Absolute O/P of $V < 38\text{ mV}$ is error state
- $C_{out} = 1\mu\text{F}$
- $R_{out} = 6\text{K}3\text{ Ohm}$
- Signal has 5V6 zener and 4k7 resistance to pin

Intrinsic Safety Documentation

- Power Rail (with solder blob)
 - ▶ $U_i = 5.0\text{V}$
 - ▶ $I_i = 220\text{mA}$ continuous
 - ▶ $P_i = 1.1\text{W}$ (see below)
 - ▶ Surge = $< 3.3\text{A}$
 - ▶ $C_i = 7\mu\text{F}$
 - ▶ $L_i = 0$
- Power Rail (without solder blob)
 - ▶ $U_i = 10.0\text{V}$
 - ▶ $I_i = 220\text{mA}$ continuous
 - ▶ $P_i = 1.1\text{W}$ (see below)
 - ▶ Surge = $< 3.3\text{A}$
 - ▶ $C_i = 1.1\mu\text{F}$
 - ▶ $L_i = 0$
- Signal out
 - ▶ $U_i = 10\text{V}$
 - ▶ $I_i = 10\text{mA}$ continuous
 - ▶ $P_i = 50\text{mW}$
 - ▶ $C_i = 0.12\mu\text{F}$
 - ▶ $L_i = 0$

Hazardous Locations Approvals

Baseefa 07ATEX0060U ETL and CETL
 IECEx BAS07.0030U Class 1, Division 1, Groups A,B,C,D
 II 1G Ex ia IIC T4 Conforms to UL STD 913 and certified to CSA STD 22.2 No 157
 Temperature range $-40^\circ\text{C} < T_a < +55^\circ\text{C}$ @ 1.1 W [$+60^\circ\text{C}$ @ 1.0 W, 65°C @ 0.9 W].