

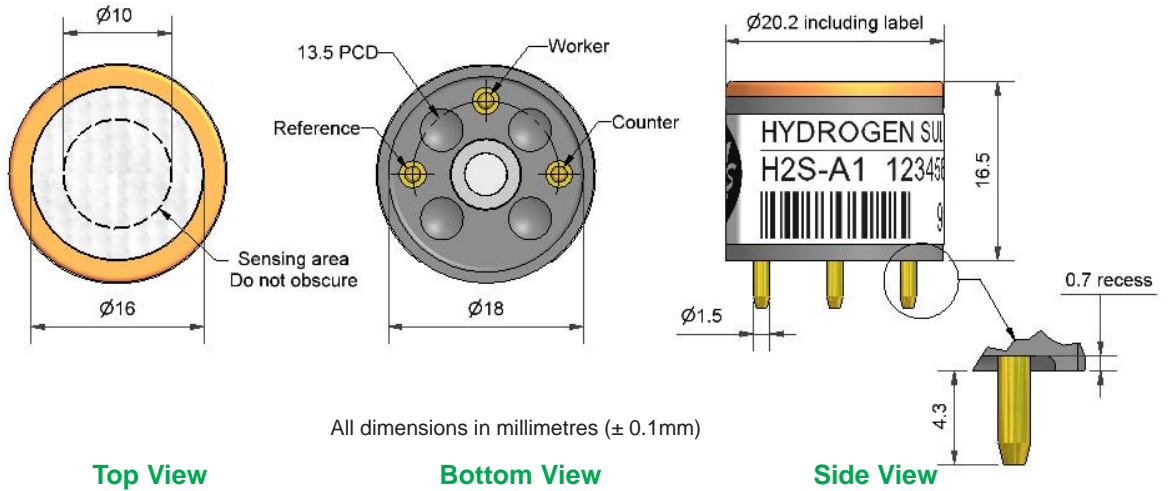

# H2S-A1 Hydrogen Sulfide Sensor



Figure 1 H2S-A1 Schematic Diagram



# Technical Specification

<b>PERFORMANCE</b>	Sensitivity	nA/ppm in 20ppm H <sub>2</sub> S	550 to 875
	Response time	t <sub>90</sub> (s) from zero to 20ppm H <sub>2</sub> S	<30
	Zero current	ppm equivalent in zero air	< $\pm 0.3$
	Resolution	RMS noise (ppm equivalent)	<0.05
	Range	ppm H <sub>2</sub> S limit of performance warranty	100
	Linearity	ppm error at full scale, linear at zero and 20ppm H <sub>2</sub> S	0 to -4
	Overgas limit	maximum ppm for stable response to gas pulse	500
<b>LIFETIME</b>	Zero drift	ppm equivalent change/year in lab air	<0.1
	Sensitivity drift	% change/year in lab air, monthly test	<3
	Operating life	months until 80% original signal (24 month warranted)	>24
<b>ENVIRONMENTAL</b>	Sensitivity @ -20°C	% (output @ -20°C/output @ 20°C) @ 20ppm	78 to 93
	Sensitivity @ 50°C	% (output @ 50°C/output @ 20°C) @ 20ppm	100 to 110
	Zero @ -20°C	ppm equivalent change from 20°C	< $\pm 0.2$
	Zero @ 50°C	ppm equivalent change from 20°C	< $\pm 0.2$
<b>CROSS SENSITIVITY</b>	NO <sub>2</sub> sensitivity	% measured gas @ 10ppm	<-20
	Cl <sub>2</sub> sensitivity	% measured gas @ 10ppm	<-25
	NO sensitivity	% measured gas @ 50ppm	<4
	SO <sub>2</sub> sensitivity	% measured gas @ 20ppm	<10
	CO sensitivity	% measured gas @ 400ppm	<1.5
	H <sub>2</sub> sensitivity	% measured gas @ 400ppm	<0.2
	C <sub>2</sub> H <sub>4</sub> sensitivity	% measured gas @ 400ppm	<0.5
NH <sub>3</sub> sensitivity	% measured gas @ 20ppm	<0.1	
<b>KEY SPECIFICATIONS</b>	Temperature range	°C	-30 to 50
	Pressure range	kPa	80 to 120
	Humidity range	% rh continuous	15 to 90
	Storage period	months @ 3 to 20°C (stored in sealed pot)	6
	Load resistor	$\Omega$ (recommended)	10 to 47
	Weight	g	<6



At the end of the product's life, do not dispose of any electronic sensor, component or instrument in the domestic waste, but contact the instrument manufacturer, Alphasense or its distributor for disposal instructions.

**NOTE:** all sensors are tested at ambient environmental conditions, with 10 ohm load resistor, unless otherwise stated. As applications of use are outside our control, the information provided is given without legal responsibility. Customers should test under their own conditions, to ensure that the sensors are suitable for their own requirements.



# H2S-A1 Performance Data

# Technical Specification

Figure 2 Sensitivity Temperature Dependence

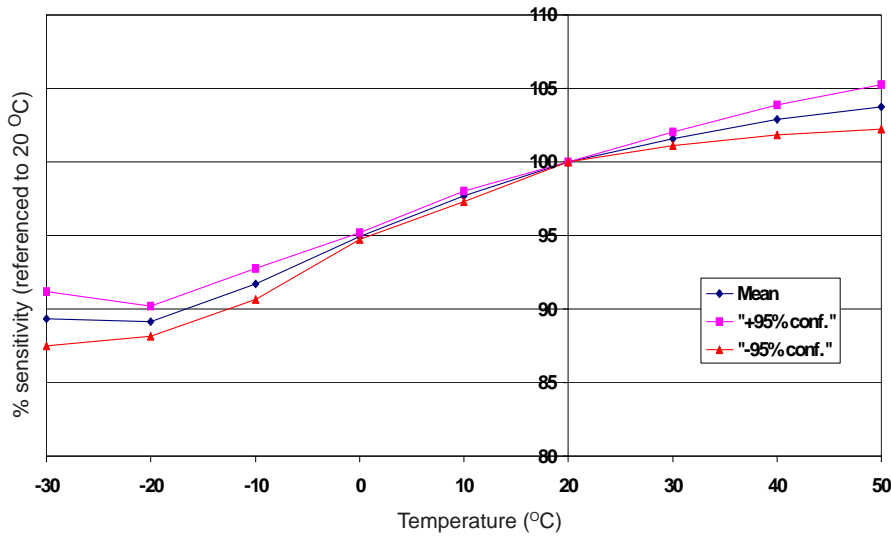

Figure 2 shows the variation in sensitivity caused by changes in temperature.

This data is taken from a typical batch of sensors. The mean and  $\pm 95\%$  confidence intervals are shown.

Figure 3 Zero Temperature Dependence

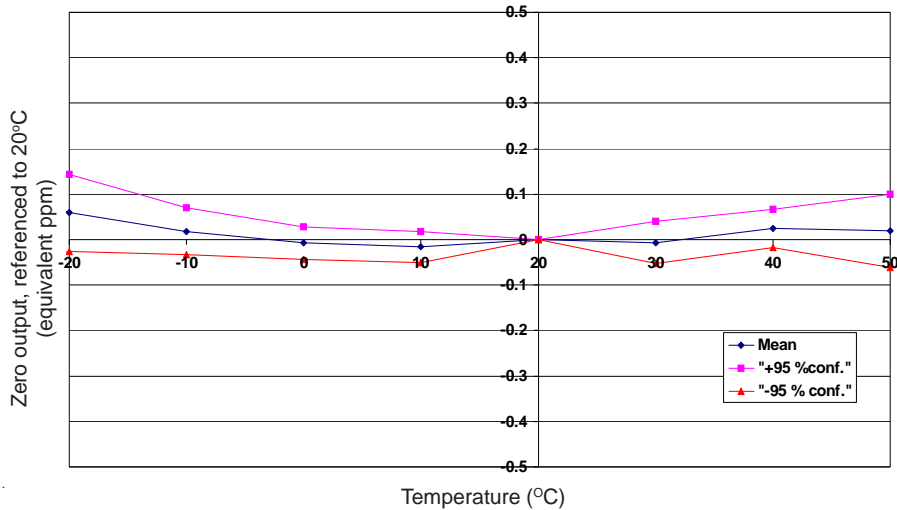

Figure 3 shows the variation in zero output caused by changes in temperature, expressed as ppm gas equivalent.

This data is taken from a typical batch of sensors. The mean and  $\pm 95\%$  confidence intervals are shown.

Figure 4 Sensitivity Long Term Stability

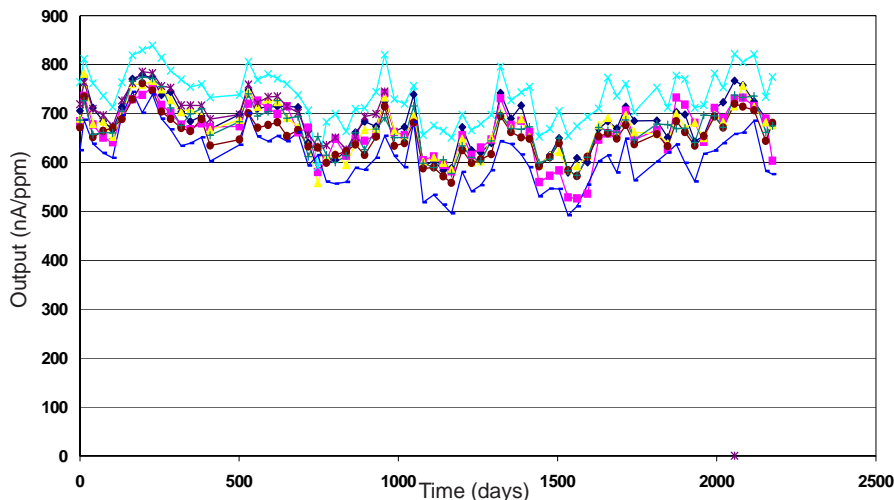

Figure 4 shows the excellent long term stability of the H2S-A1, which results from the combination of a patented design, superior electrochemistry and good process control.

For further information on the performance of this sensor, on other sensors in the range or any other subject, please contact Alphasense Ltd. For Application Notes visit "[www.alphasense.com](http://www.alphasense.com)".

*In the interest of continued product improvement, we reserve the right to change design features and specifications without prior notification. The data contained in this document is for guidance only. Alphasense Ltd accepts no liability for any consequential losses, injury or damage resulting from the use of this document or the information contained within. (©ALPHASENSE LTD) Doc. Ref. H2SA1/JUN11*