



4 to 20 mA Digital Transmitter Board

Alphasense A and B Type Toxic Gas Sensors

Technical Specification



Alphasense digital transmitters offer the following features:

- Factory calibration for immediate use
- Custom-set range to your requirements
- Digital temperature compensation
- Digital and 4-20mA output
- Biased or unbiased operation

Alphasense 4-20mA digital transmitter boards provide a cost effective way for Original Equipment Manufacturers to include 4-20mA gas sensor transmitters for fixed installation systems. The range of sensors are shown in Table 1 (over). The boards supplied with sensors are pre-calibrated.

The 4-20 mA output signal provides an equivalent performance to that shown in individual sensor data sheets provided for each of the Alphasense A and B Series Toxic gas sensors.

Each board is provided with set of mounting pillars for location of the board into an enclosure. To allow OEMs to distinguish their product from other offerings, the sensor to gas aperture design is left to the OEM to execute.

Table 1. Transmitter Board and Sensors

GAS	SENSOR TYPE A	MAXIMUM GAS CONCENTRATION (ppm)	SENSOR TYPE B	MAXIMUM GAS CONCENTRATION (ppm)
Carbon Monoxide	CO-AF*	5,000	CO-BF*	5,000
	CO-AE*	10,000		
	CO-AX*	2,000	CO-BX*	2,000
Hydrogen Sulfide	H2S-A1*	100	H2S-B1*	200
	H2S-AH*	50	H2S-BH*	50
	H2S-AE*	2,000	H2S-BE*	2,000
Sulfur Dioxide	SO2-AF	20	SO2-BF*	100
	SO2-AE*	2,000		
Nitrogen Dioxide	NO2-A1	20	NO2-B1*	20
Chlorine	CL2-A1	20	CL2-B1*	20
Nitric Oxide**	NO-A1*	250	NO-B1*	250
	NO-AE*	5,000		
Phosphene	PH3-A1	10	PH3-B1*	10
Ethylene Oxide**	ETO-A1*	100	ETO-B1	100
Hydrogen Cyanide	HCN-A1*	100		
Hydrogen Chloride	HCL-A1	200		

* Recommended sensor

** Biased sensors require at least 12 hours to stabilise after first powered on

Specify preferred full scale gas concentration with your order, up to maximum concentration.



4 to 20 mA Digital Transmitter Board Alphasense A and B Type Toxic Gas Sensors

Technical Specification

Transmitter Board Dimension Details

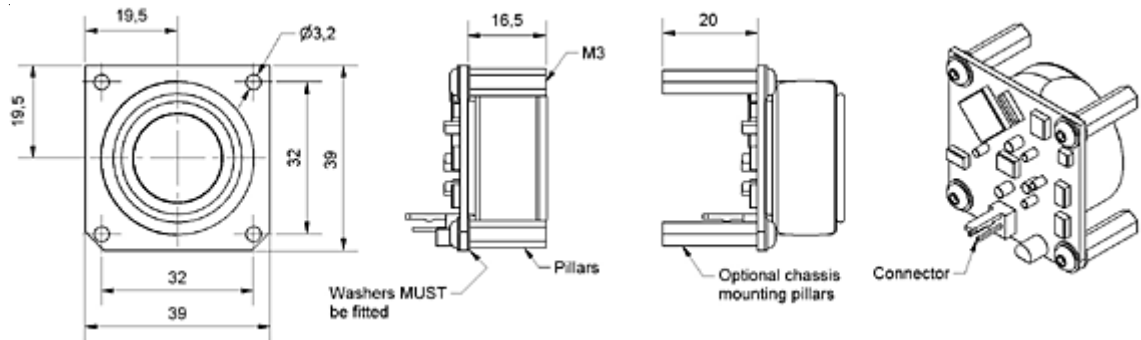

INPUT	Type: 3-wire gas sensor: series A or series B Range: -220uA to +320 uA Minimum span: $\pm 3 \mu\text{A}$ Sample rate: 500ms per sample Thermal drift: $0.05 \mu\text{A}/^\circ\text{C}$ Protection: Power off shorting FET Resolution: 11 nA Bias: Selectable off, +200 and +300mV ($\pm 10 \text{ mV}$ tolerance) Temperature compensation: On-board temperature sensor range -30°C to $60^\circ\text{C} \pm 0.5^\circ\text{C}$ for software correction of Zero and Span Connection: 2-pin MOLEX plug (ref 22-27-2021)
OUTPUT	Type: 4 mA to 20 mA 2-wire loop powered Maximum output: 3.8 mA to 21.5mA Operating voltage: 10 to 30 VDC Accuracy: $\pm 5 \mu\text{A}$ Sensor out of range: Up Scale > 21.5mA Supply sensitivity: $< 0.03\%$ 10 to 30 VDC Loop ripple effect: $\pm 2 \mu\text{A}$ measure @ 1 volt RMS 50Hz supply ripple Thermal drift: $\pm 0.2 \mu\text{A} / ^\circ\text{C}$ Maximum loop resistance: 700 R @ 24 VDC Resolution: $0.75 \mu\text{A}$ Protection: Reverse connection protected and over voltage Connection: 2-Pin MOLEX plug (Ref. 22-27-2021)
GENERAL	Warm-up time: 2 minutes to full accuracy
ENVIRONMENT	Ambient temperature: -30°C to 60°C Ambient storage: -40°C to 70°C Ambient humidity: 0% to 95% continuous (non-condensing) Coating: Conformal spray coated
CE APPROVAL	BS EN 61326 (Industrial)

For further information on the performance of sensors in the Alphasense range or any other subject, please contact Alphasense Ltd. For Application Notes visit "www.alphasense.com"

NOTE: as applications of use are beyond our control, the information provided is given without legal responsibility. Customers should test under their own conditions, to ensure that the sensors and transmitters are suitable for their own requirements.

In the interest of continued product improvement, we reserve the right to change design features and specifications without prior notification. The data contained in this document is for guidance only. Alphasense Ltd accepts no liability for any consequential losses, injury or damage resulting from the use of this document or the information contained in it (©ALPHASENSE LTD) Doc. Ref. 4-20mA Digital/JUN11