



Dual Sensor Carbon Monoxide/Hydrogen Sulfide Miniature Size



PATENTED and PATENT PENDING

Technical Specification

Introduction

The world wide use of multigas, portable, personal safety monitors has grown since the 1970s to include an ever increasing number of industries. The one requirement in common to the majority of these instruments is the need to measure both Carbon Monoxide and Hydrogen Sulfide simultaneously.

Alphasense now offers a compact, dual gas sensor which allows designers to reduce significantly instrument size and cost. The CD₂ sensor provides a unique approach to the dual gas sensor in both its size and working electrode configuration. The use of a high capacity filter over the Carbon Monoxide working electrode eliminates Carbon Monoxide cross sensitivity to Hydrogen Sulfide.

Adoption of the CD₂ portable instrument designs enables accurate factory, service and field calibration of instruments using multi-component gases without the fear of incorrect calibration of the Carbon Monoxide channel, providing reduced instrument manufacturing and service costs.

D2 Specification Carbon Monoxide Channel

PERFORMANCE	Sensitivity	nA/ppm in 400ppm CO	30 to 55
	Response time	t ₉₀ (s) from zero to 400ppm CO	< 25
	Zero current	ppm equivalent in zero air	< ± 6
	Resolution	rms noise (ppm equivalent)	1
	Range	ppm CO limit of performance warranty	1000
	Linearity	ppm error at full scale, linear at zero and 400 ppm CO	< 40
	Overgas limit	maximum CO for stable response to gas pulse	5000
LIFETIME	Zero drift	ppm equivalent change/year in lab air	<0.5
	Sensitivity drift	% change/year in lab air, monthly test	<4
	Operating life	months until 80% original signal (24 month warranted)	24
ENVIRONMENTAL	Sensitivity @ -20°C	% (output @ -20°C/output @ 20°C) @ 100ppm CO	61 to 78
	Sensitivity @ 50°C	% (output @ 50°C/output @ 20°C) @ 100ppm CO	105 to 115
	Zero @ -20°C	ppm equivalent change from 20°C	-1 to 1
	Zero @ 50°C	ppm equivalent change from 20°C	-1 to 4
CROSS SENSITIVITY	Filter Capacity	ppm-hoursof Hydrogen Sulfide	15,000
	H ₂ S sensitivity	% measured gas @ 20ppm H ₂ S	< 8
	NO ₂ sensitivity	% measured gas @ 10ppm NO ₂	< 0.1
	Cl ₂ sensitivity	% measured gas @10ppm Cl ₂	< 0.1
	NO sensitivity	% measured gas @ 50ppm NO	< 50
	SO ₂ sensitivity	% measured gas @ 20ppm SO ₂	< 0.1
	H ₂ sensitivity	% measured gas @ 400ppm H ₂ @ 20°C	< 55
NH ₃ sensitivity	% measured gas @ 20ppm NH ₃	< 0.1	
KEY SPECIFICATIONS	Temperature range	°C	-30 to 50
	Pressure range	kPa	80 to 120
	Humidity range	%rh continuous (see note below)	15 to 90
	Storage period	months @ 3 to 20°C (stored in sealed pot)	6
	Load resistor	Ω (recommended)	10 to 47
	Weight	g	< 2

Note: Above 85% rh and 40°C a maximum continuous exposure period of 10 days is warranted. Where such exposure occurs the sensor will recover normal electrolyte volumes, when allowed to rest at lower %rh and temperature levels for several days.



At the end of the product's life, do not dispose of any electronic sensor, component or instrument in the domestic waste, but contact the instrument manufacturer, Alphasense or its distributor for disposal instructions.

NOTE: all sensors are tested at ambient environmental conditions, with 10 ohm load resistor, unless otherwise stated. As applications of use are outside our control, the information provided is given without legal responsibility. Customers should test under their own conditions, to ensure that the sensors are suitable for their own requirements.



Performance Data Carbon Monoxide Channel

Technical Specification

Figure 2 CO Channel Sensitivity Temperature Dependence

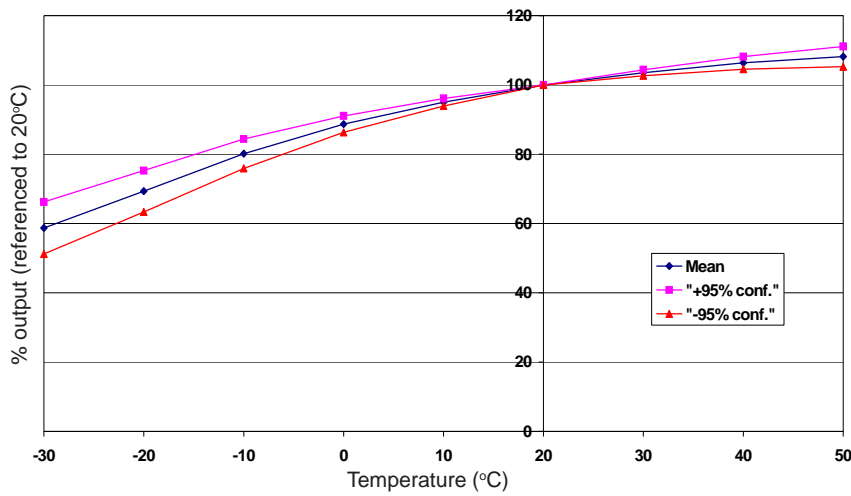

Figure 2 shows the variation in sensitivity caused by changes in temperature. The data is taken from a typical batch of sensors.

Figure 3 CO Channel Zero Temperature Dependence

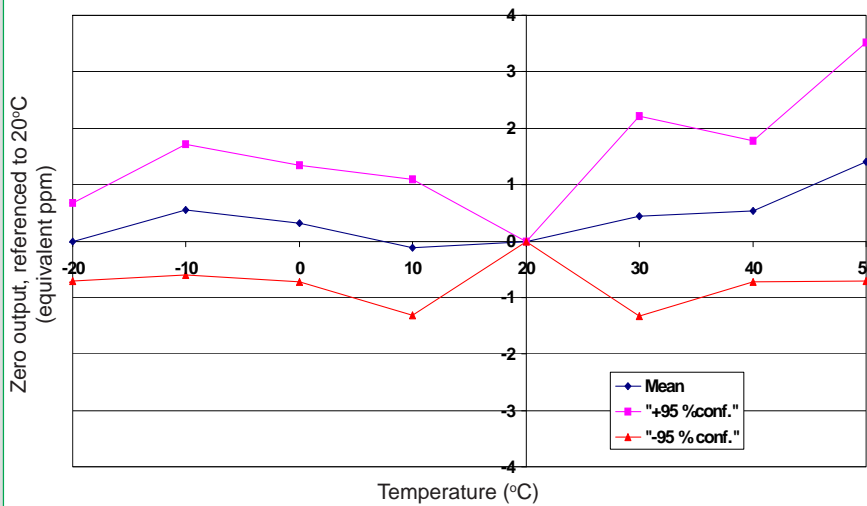

Figure 3 shows the variation in zero output caused by changes in temperature, expressed as ppm gas equivalent.

This data is taken from a typical batch of sensors and shows the $\pm 95\%$ confidence intervals, referenced to 20°C.

Figure 4 CO Channel Response to High CO Concentration

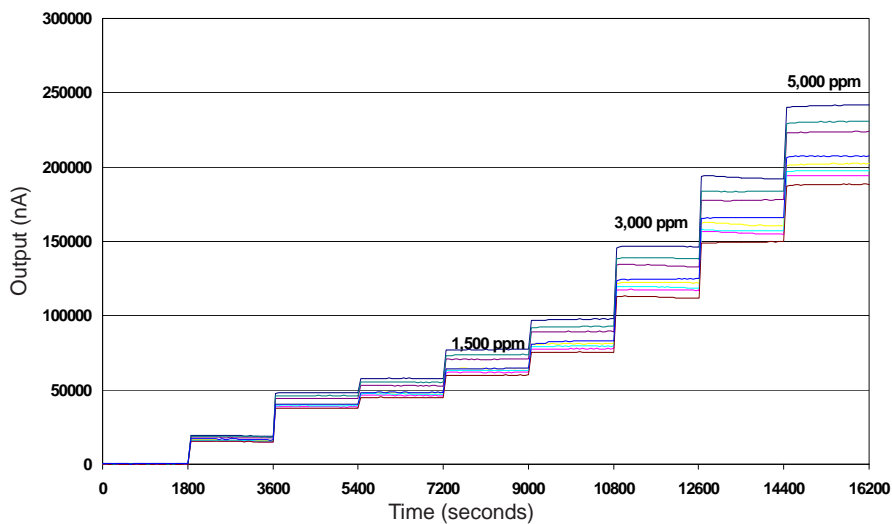

Figure 4 shows the response for a batch of D2 sensors tested with CO gas up to 5000ppm. The fast, stable response shows a robust sensor that operates well above its specification.



CD₂TM

Performance Specification continued



Figure 1 D2 Schematic Diagram

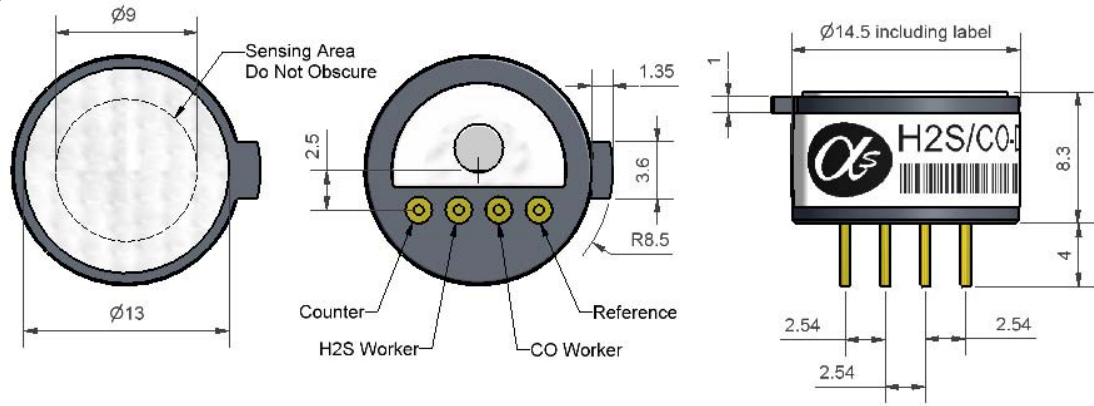

All dimensions in millimetres ± 0.1

Top View

Bottom View

Side View

D2 Specification Hydrogen Sulfide Channel

PERFORMANCE	Sensitivity	nA/ppm in 20ppm H ₂ S	90 to 150
	Response time	t ₉₀ (s) from zero to 20ppm H ₂ S @ 20°C	< 30
	Zero current	ppm equivalent in zero air	< ± 0.6
	Resolution	rms noise (ppm equivalent)	< 0.25
	Range	ppm H ₂ S limit of performance warranty	100
	Linearity	ppm error at full scale, linear at zero and 20ppm H ₂ S	0 to -9
	Overgas limit	maximum ppm H ₂ S for stable response to gas pulse	400
LIFETIME	Zero drift	ppm equivalent change/year in lab air	< 0.1
	Sensitivity drift	% change/year in lab air, monthly test	< 2
	Operating life	months until 80% original signal (24 month warranted)	24
ENVIRONMENTAL	Sensitivity @ -20°C	% (output @ -20°C/output @ 20°C) @ 20ppm H ₂ S	75 to 90
	Sensitivity @ 50°C	% (output @ 50°C/output @ 20°C) @ 20ppm H ₂ S	103 to 112
	Zero @ -20°C	ppm equivalent change from 20°C	-0.3 to 0.2
	Zero @ 50°C	ppm equivalent change from 20°C	-1 to 0
CROSS SENSITIVITY	NO ₂	sensitivity % measured gas @ 10ppm NO ₂	< -10
	Cl ₂	sensitivity % measured gas @ 10ppm Cl ₂	< -10
	NO	sensitivity % measured gas @ 50ppm NO	< 10
	SO ₂	sensitivity % measured gas @ 20ppm SO ₂	< 10
	CO	sensitivity % measured gas @ 400ppm CO	< 2
	H ₂	sensitivity % measured gas @ 400ppm H ₂	< 1
	C ₂ H ₄	sensitivity % measured gas @ 400ppm C ₂ H ₄	< 1
NH ₃	sensitivity % measured gas @ 20ppm NH ₃	0	

***Note:** Above 85% rh and 40°C a maximum continuous exposure period of 10 days is warranted. Where such exposure occurs, the sensor will recover normal electrolyte volumes when allowed to rest at lower %rh and temperature levels for several days.

Technical Specification



Performance Data Hydrogen Sulfide Channel

Technical Specification

Figure 5 H₂S Channel Sensitivity Temperature Dependence

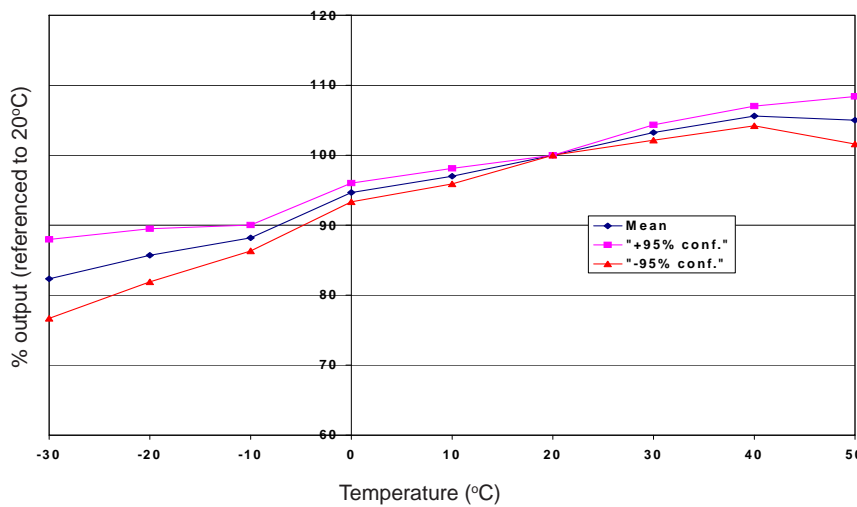

Figure 5 shows the variation in sensitivity caused by changes in temperature. The data is taken from a typical batch of sensors.

Figure 6 H₂S Channel Zero Temperature Dependence

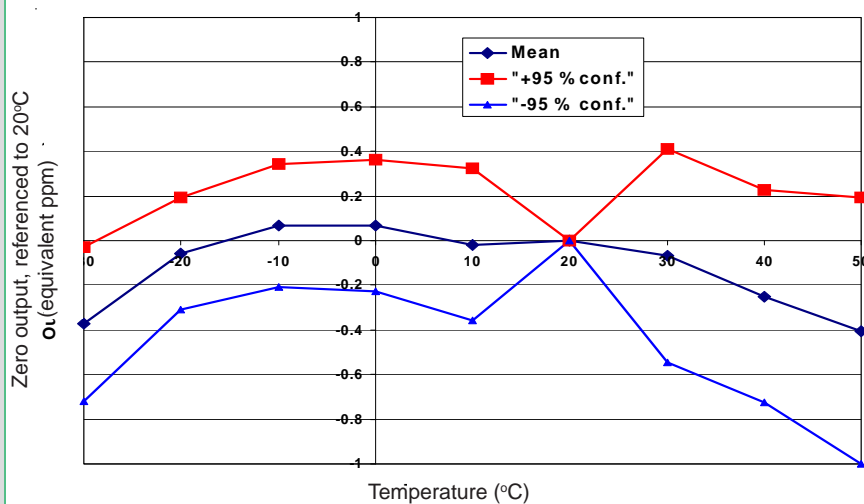

Figure 6 shows the variation in zero output caused by changes in temperature, expressed as ppm gas equivalent.

This data is taken from a typical batch of sensors and shows the $\pm 95\%$ confidence intervals, referenced to 20°C.

Figure 7 Ambient Long Term Test Results

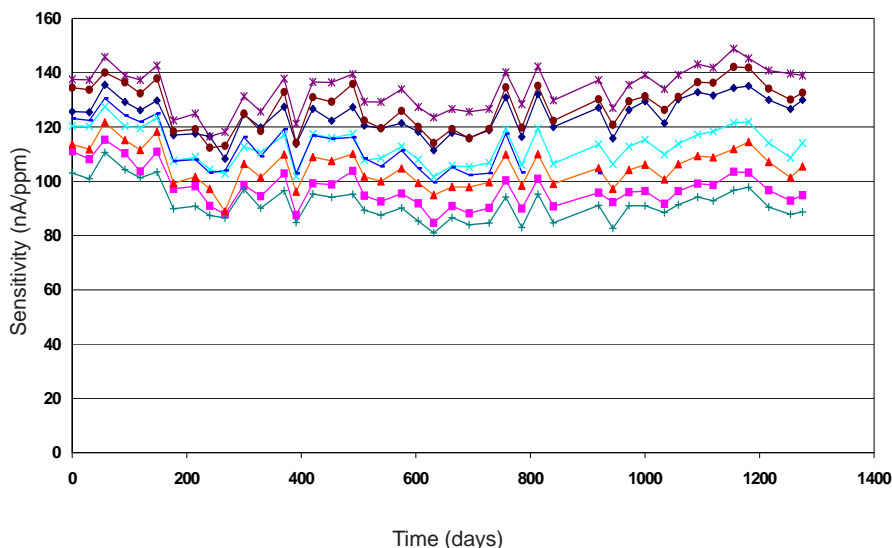

Figure 7 shows good long term stability of the D2.

Sensors were tested monthly and stored in ambient laboratory conditions.

For further information on the performance of this sensor, on other sensors in the range or any other subject, please contact Alphasense Ltd or access our web site at "www.alphasense.com".

In the interest of continued product improvement, we reserve the right to change design features and specifications without prior notification. The data contained in this document is for guidance only. Alphasense Ltd accepts no liability for any consequential losses, injury or damage resulting from the use of this document or the information contained within (©ALPHASENSE LTD) Doc. Ref D2/MAR11