



CO-BX Carbon Monoxide Sensor

Low Hydrogen Cross Sensitivity



PATENTED

Figure 1 CO-BX Schematic Diagram

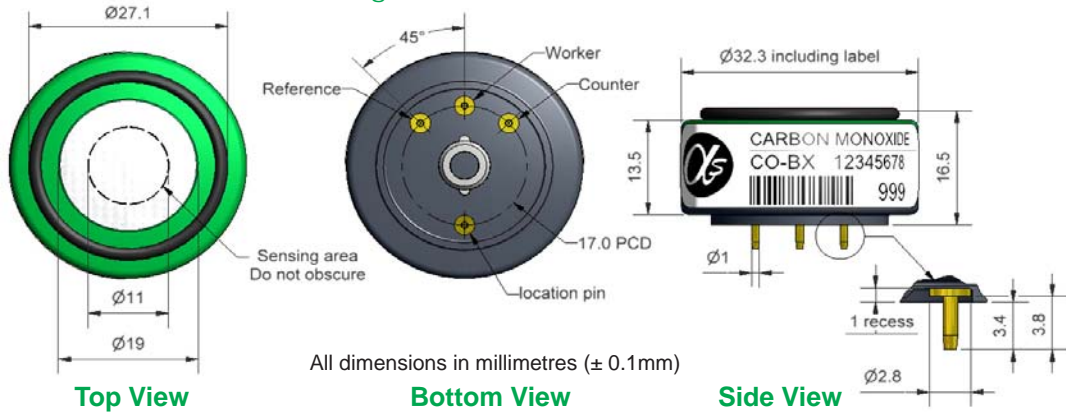

Technical Specification

PERFORMANCE	Sensitivity	nA/ppm in 400ppm CO	70 to 120
	Response time	t_{90} (s) from zero to 400ppm CO	< 40
	Zero current	ppm equivalent in zero air	-4 to +2
	Resolution	RMS noise (ppm equivalent)	< 0.5
	Range	ppm limit of performance warranty	2,000
	Linearity	ppm CO error at full scale, linear at zero, 400ppm CO	< ± 5
	Overgas limit	maximum ppm for stable response to gas pulse	5,000
LIFETIME	Zero drift	ppm equivalent change/year in lab air	< 0.2
	Sensitivity drift	% change/year in lab air, monthly test	< 3
	Operating life	months until 80% original signal (24 month warranted)	> 24
ENVIRONMENTAL	Sensitivity @ -20°C	% (output @ -20°C/output @ 20°C) @ 400ppm CO	40 to 75
	Sensitivity @ 0°C	% (output @ 0°C/output @ 20°C) @ 400ppm CO	65 to 80
	Sensitivity @ 50°C	% (output @ 50°C/output @ 20°C) @ 400ppm CO	110 to 135
	Zero @ -20°C	ppm equivalent change from 20°C	± 5
	Zero @ 0°C	ppm equivalent change from 20°C	± 1
	Zero @ 50°C	ppm equivalent change from 20°C	< ± 8
CROSS SENSITIVITY	Filter capacity	ppm-hrs	H ₂ S 160,000
	Filter capacity	ppm-hrs	NO ₂ 120,000
	Filter capacity	ppm-hrs	NO 120,000
	Filter capacity	ppm-hrs	SO ₂ 160,000
	H ₂ S sensitivity	% measured gas @ 20ppm	H ₂ S < 0.1
	NO ₂ sensitivity	% measured gas @ 10ppm	NO ₂ < 1
	Cl ₂ sensitivity	% measured gas @ 10ppm	Cl ₂ < 0.1
	NO sensitivity	% measured gas @ 50ppm	NO < 25
	SO ₂ sensitivity	% measured gas @ 20ppm	SO ₂ < 0.1
	H ₂ sensitivity	% measured gas @ 400ppm	H ₂ at 20°C < 5
C ₂ H ₄ sensitivity	% measured gas @ 400ppm	C ₂ H ₄ < 10	
NH ₃ sensitivity	% measured gas @ 20ppm	NH ₃ < 0.1	
KEY SPECIFICATIONS	Temperature range	°C	-30 to 50
	Pressure range	kPa	80 to 120
	Humidity range	% rh continuous	15 to 90
	Storage period	months @ 3 to 20°C (stored in sealed pot)	6
	Load resistor	Ω (recommended)	10 to 47
	Weight	g	< 13

Important. The CO-BX must be operated with a 0 Volt bias between Reference & Working electrodes. Failure to comply with this requirement will result in a loss of its low Hydrogen cross sensitivity performance.



At the end of the product's life, do not dispose of any electronic sensor, component or instrument in the domestic waste, but contact the instrument manufacturer, Alphasense or its distributor for disposal instructions.

NOTE: all sensors are tested at ambient environmental conditions, with 10 ohm load resistor, unless otherwise stated. As applications of use are outside our control, the information provided is given without legal responsibility. Customers should test under their own conditions, to ensure that the sensors are suitable for their own requirements.



CO-BX Performance Data

Technical Specification

Figure 2 Sensitivity Temperature Dependence

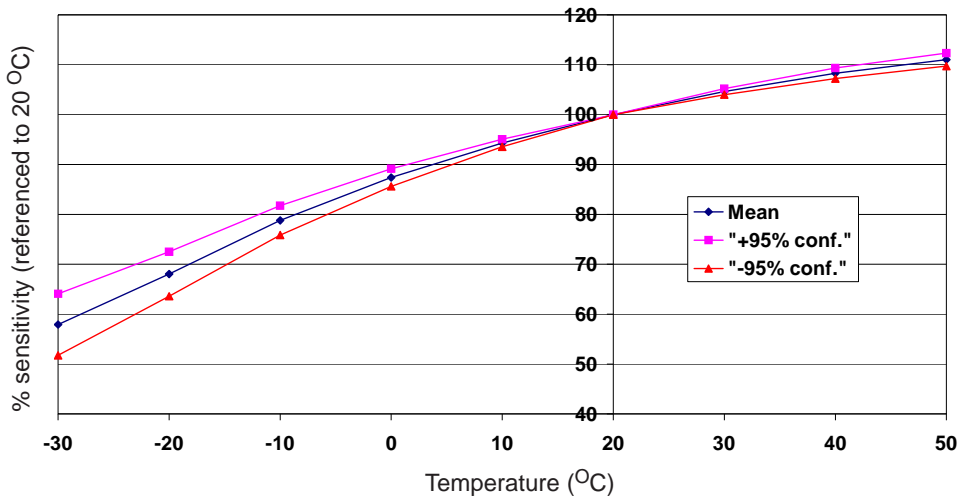

Figure 2 shows the variation in sensitivity caused by changes in temperature.

This data is taken from a typical batch of sensors. The mean and ±95% confidence intervals are shown.

Figure 3 Zero Temperature Dependence

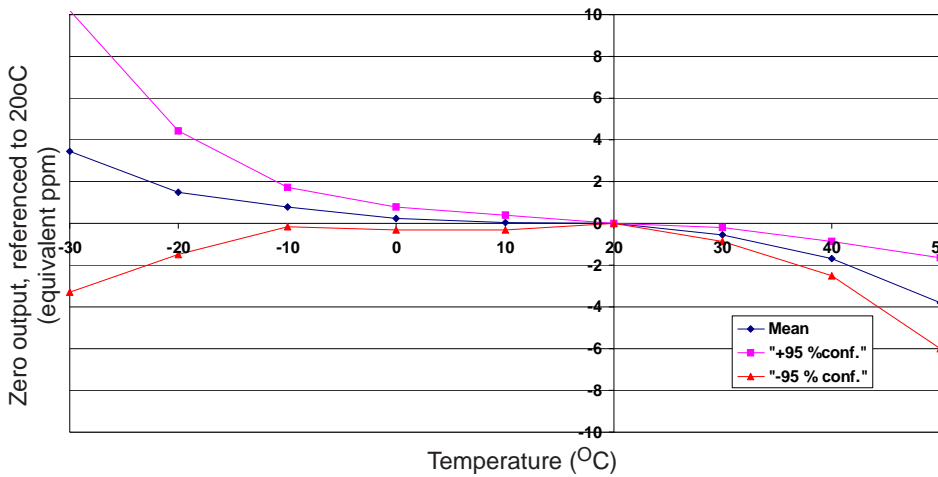
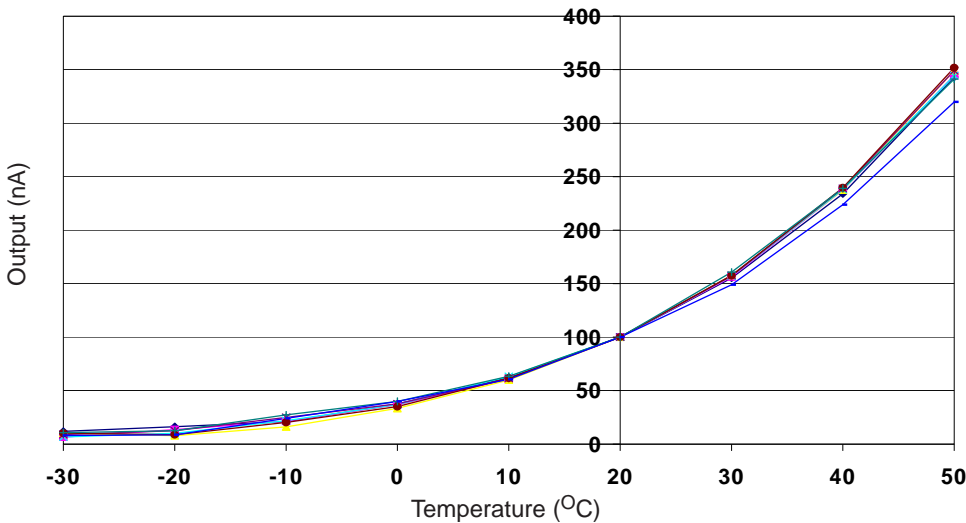

Figure 3 shows the variation in zero output caused by changes in temperature, expressed as ppm gas equivalent.

This data is taken from a typical batch of sensors. The mean and ±95% confidence intervals are shown.

Figure 4 Hydrogen Temperature Dependence



Hydrogen sensitivity is very dependent on temperature.

At low temperatures hydrogen sensitivity can be ignored, but above 30°C it is important.

For further information on the performance of this sensor, on other sensors in the range or any other subject, please contact Alphasense Ltd. For Application Notes visit "www.alphasense.com".

In the interest of continued product improvement, we reserve the right to change design features and specifications without prior notification. The data contained in this document is for guidance only. Alphasense Ltd accepts no liability for any consequential losses, injury or damage resulting from the use of this document or the information contained within. (©ALPHASENSE LTD) Doc. Ref. COBX/JUN11