



# CL2-D4 Chlorine Sensor

## Miniature Size



PATENTED

Figure 1 CL2-D4 Schematic Diagram

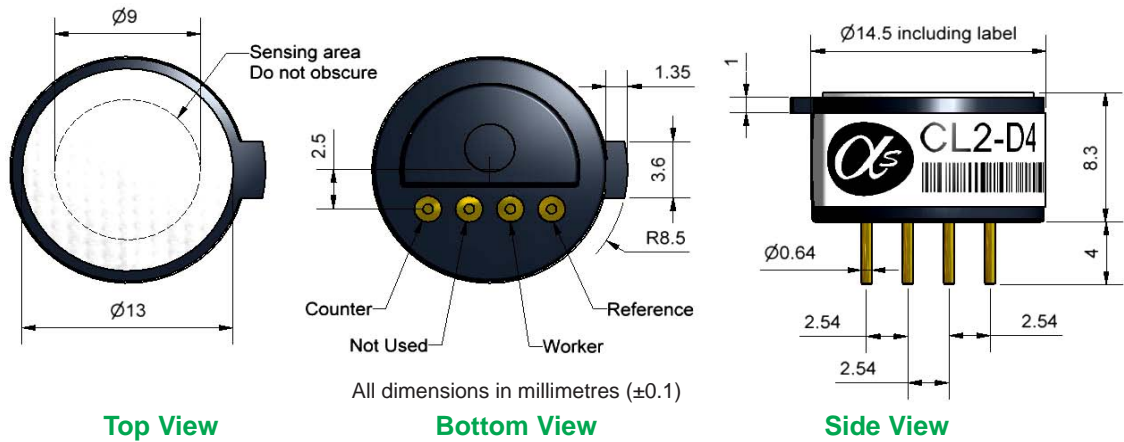

Technical Specification

PERFORMANCE	Parameter	Specification	Range
	Sensitivity	nA/ppm in 10ppm Cl <sub>2</sub>	-250 to -375
	Response time	t <sub>90</sub> (s) from zero to 10ppm Cl <sub>2</sub>	< 35
	Zero current	ppm equivalent in zero air	± 0.6
	Resolution	RMS noise (ppm equivalent)	< 0.1
	Range	ppm Cl <sub>2</sub> limit of performance warranty	20
	Linearity	ppm error at full scale, linear at zero and 10ppm Cl <sub>2</sub>	± 0.5
	Overtask limit	maximum ppm for stable response to gas pulse	60

LIFETIME	Parameter	Specification	Value
	Zero drift	ppm equivalent change/year in lab air	nd
	Sensitivity drift	% change/month in lab air, twice monthly test	nd
	Operating life	months until 80% original signal (24 month warranted)	> 24

ENVIRONMENTAL	Parameter	Specification	Value
	Sensitivity @ -20°C	% (output @ -20°C/output @ 20°C) @ 10ppm Cl <sub>2</sub>	90 to 110
	Sensitivity @ 50°C	% (output @ 50°C/output @ 20°C) @ 10ppm Cl <sub>2</sub>	110 to 130
	Zero @ -20°C	ppm equivalent change from 20°C	-0.4 to 0.4
	Zero @ 50°C	ppm equivalent change from 20°C	0 to 0.5

CROSS SENSITIVITY	Gas	Sensitivity % measured gas @	Value
	H <sub>2</sub> S	20ppm	< -20
	NO <sub>2</sub>	10ppm	< 80
	NO	50ppm	< 0.5
	SO <sub>2</sub>	20ppm	< 1
	CO	400ppm	< 0.1
	H <sub>2</sub>	400ppm	< 0.1
	C <sub>2</sub> H <sub>4</sub>	400ppm	< 0.1
	NH <sub>3</sub>	20ppm	< 0.1

KEY SPECIFICATIONS	Parameter	Specification	Value
	Temperature range	°C	-20 to 50
	Pressure range	kPa	80 to 120
	Humidity range	%rh (see note below)	15 to 90
	Storage period	months @ 3 to 20°C (stored in sealed pot)	6
	Load resistor	Ω (for optimum performance)	33
	Weight	g	< 2

Note: Above 85% rh and 40°C a maximum continuous exposure period of 10 days is warranted. Where such exposure occurs the sensor will recover normal electrolyte volumes when allowed to rest at lower % rh and temperature levels for several days.



At the end of the product's life, do not dispose of any electronic sensor, component or instrument in the domestic waste, but contact the instrument manufacturer, Alphasense or its distributor for disposal instructions.

NOTE: all sensors are tested at ambient environmental conditions, with 10 ohm load resistor, unless otherwise stated. As applications of use are outside our control, the information provided is given without legal responsibility. Customers should test under their own conditions, to ensure that the sensors are suitable for their own requirements.



# CL2-D4 Performance Data

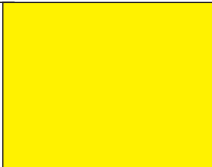

Technical Specification

Figure 2 Response to 10ppm Cl<sub>2</sub>

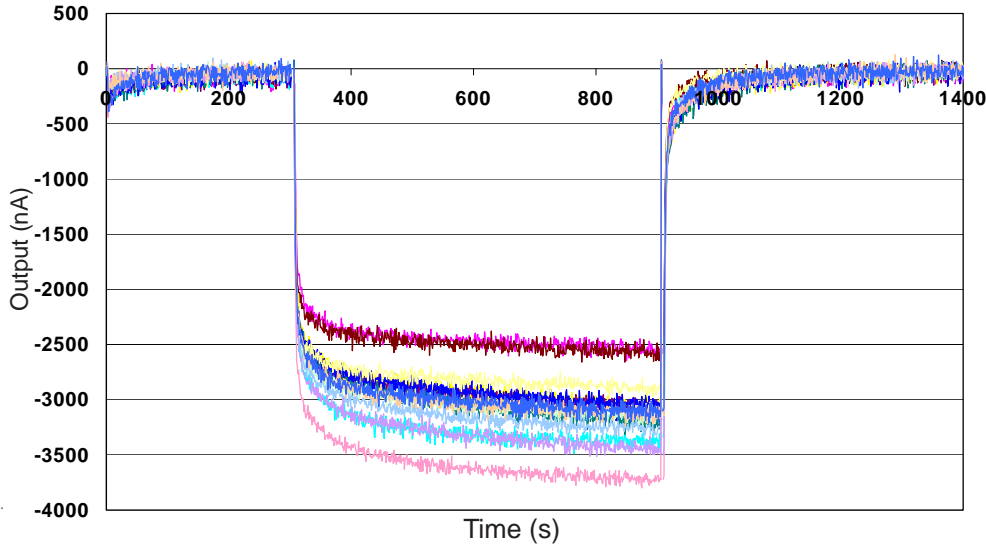

Figure 2 shows response to 10ppm Cl<sub>2</sub>.

This data is taken from a typical batch of sensors.

Figure 3 Zero Temperature Dependence

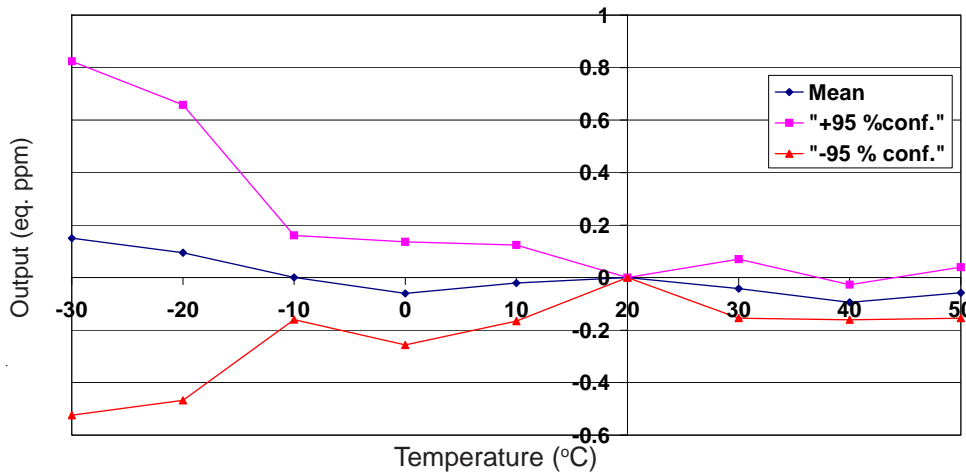

Figure 3 shows the variation in the zero by changes in temperature.

This data is taken from a typical batch of sensors. The mean and ±95% confidence intervals are shown.

Figure 4 Load Resistor Dependence

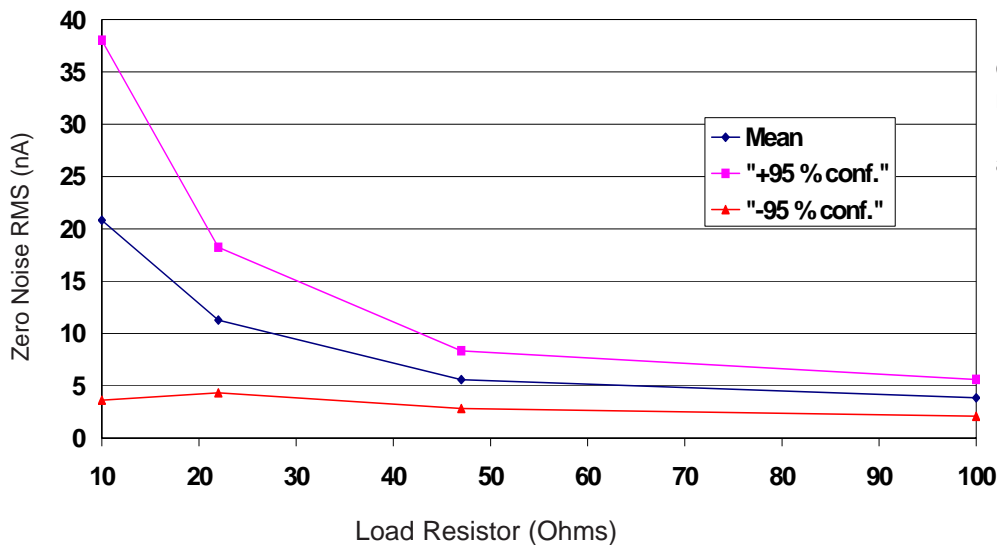

Figure 4 shows the effect of the load resistor on noise. Higher resistance reduces sensor noise, but also linearly increases response time.

For further information on the performance of this sensor, on other sensors in the range or any other subject, please contact Alphasense Ltd. or visit our web site at "[www.alphasense.com](http://www.alphasense.com)".

In the interest of continued product improvement, we reserve the right to change design features and specifications without prior notification. The data contained in this document is for guidance only. Alphasense Ltd accepts no liability for any consequential losses, injury or damage resulting from the use of this document or the information contained within. ©ALPHASENSE LTD) Doc. Ref. CL2D4/JUN11