



# p-Type Metal Oxide Sensor Overview



# Technical Specification

Alphasense introduces a new class of metal oxide gas sensors.

Commercially available metal oxide sensors are based on n-type metal oxides: SnO<sub>2</sub> or WO<sub>3</sub>. With low base resistance, those n-type sensors are simple to manufacture and operate at lower temperatures, but suffer from three problems:

- baseline drift
- humidity sensitivity
- negative response to gases (potentially an unsafe response)

Developed over many years, our **p-type metal oxide** gas sensors offer the following benefits:

- stable baseline
- low humidity sensitivity
- positive response to gases (safer response)

Three sensors have been developed for specific markets:

- H<sub>2</sub>S detection at high temperatures (up to 120°C) for oil and gas applications
- Volatile Organic Compounds (VOCs) detection for low cost IAQ applications
- CO detection for extreme temperature or humidity environments

Each sensor type can be supplied in three housings (see figures 1 - 4 for housing dimensions)

- TO-5 metal can, the most common format
- Plastic 6-pin housing - frequently used with other metal oxide gas sensors
- Ex housing\* - stainless steel 316 housing with UL, CSA, ATEX and IECEx approvals, unique for metal oxides, allowing use in hazardous areas without the need for an IS circuit

\* Refer to the following pages for Ex specifications.

**Table 1 Ordering information**

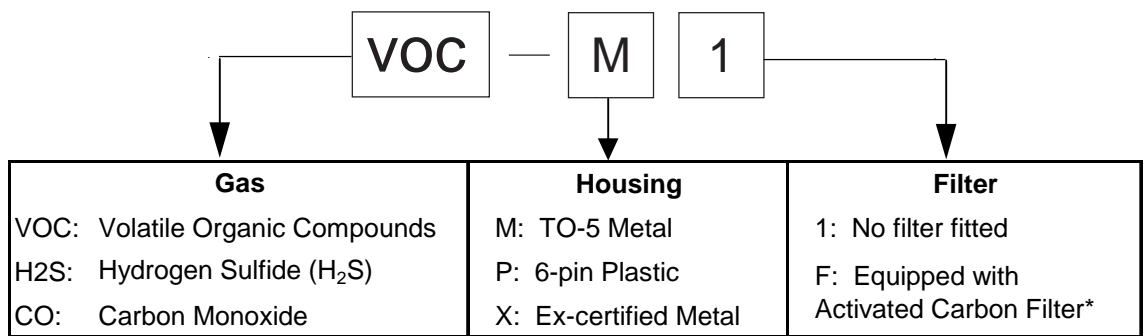

\* Only available for CO series

Alphasense p-type sensors can be operated at constant heater voltage/ constant temperature (400°C), but performance is improved when the sensors are refreshed periodically at a higher temperature (525°C).

Typical sense:refresh time ratio is 5:1, however with application optimisation even higher sensitivities can be achieved. Refer to our Application Notes for more information.

Evaluation board 810-0028-00 is available for use with our MOS sensors.





# p-Type Metal Oxide Sensor Overview



Technical Specification

Figure 1 Schematic Diagram (MFF housing)

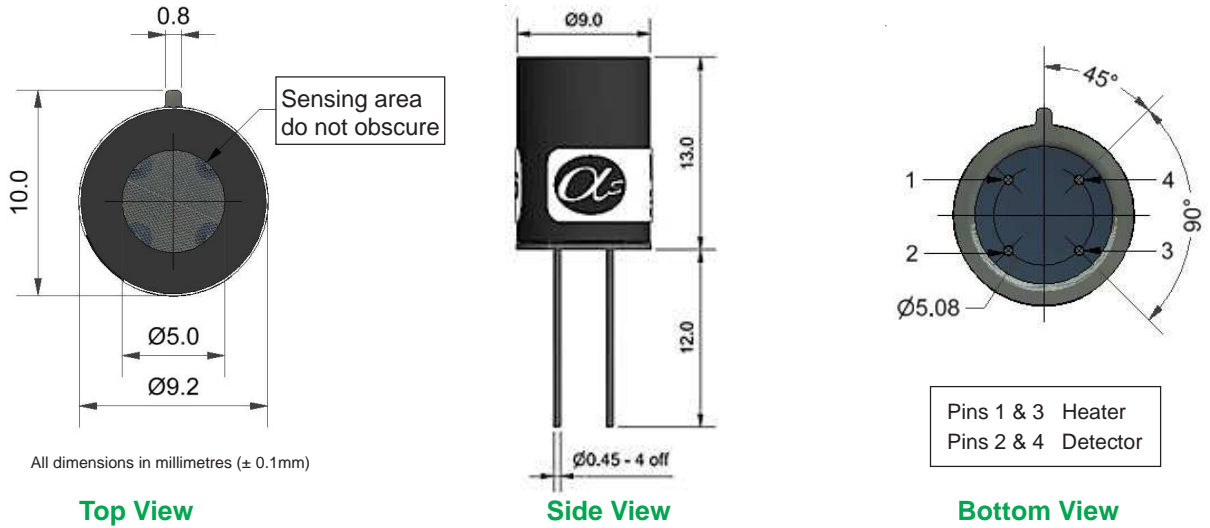

Figure 2 Schematic Diagram (MF1 Housing, 7.7mm TO-5 can)

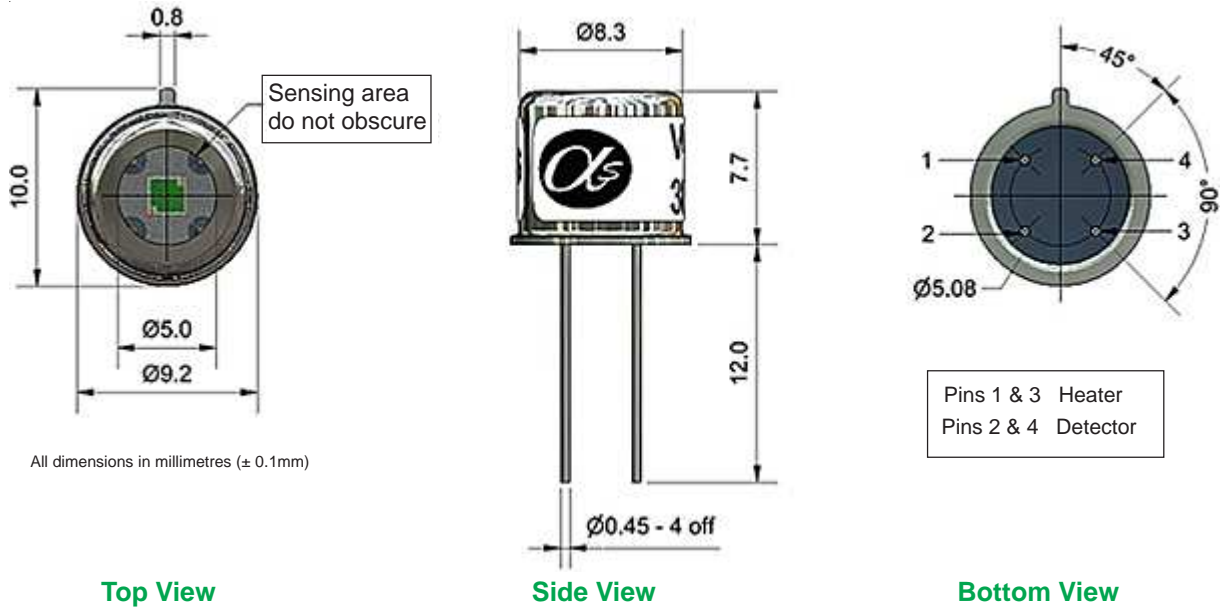
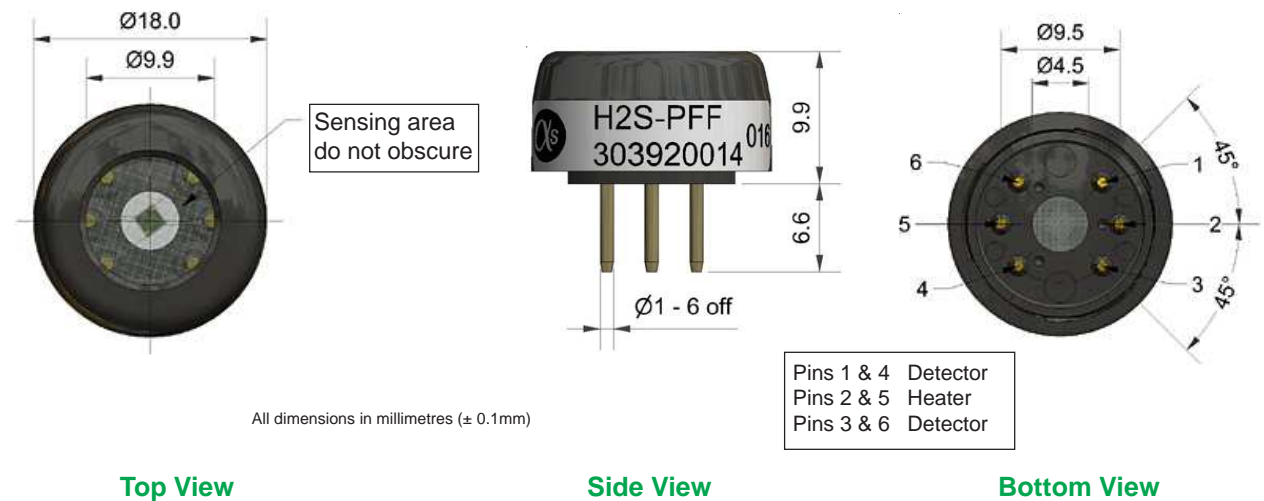

Figure 3 Schematic Diagram (PF1 and PFF Plastic Housing)





# p-Type Metal Oxide Sensor Overview



Technical Specification

**Figure 4 Schematic Diagram (AF1 and AFF Ex Housing)**

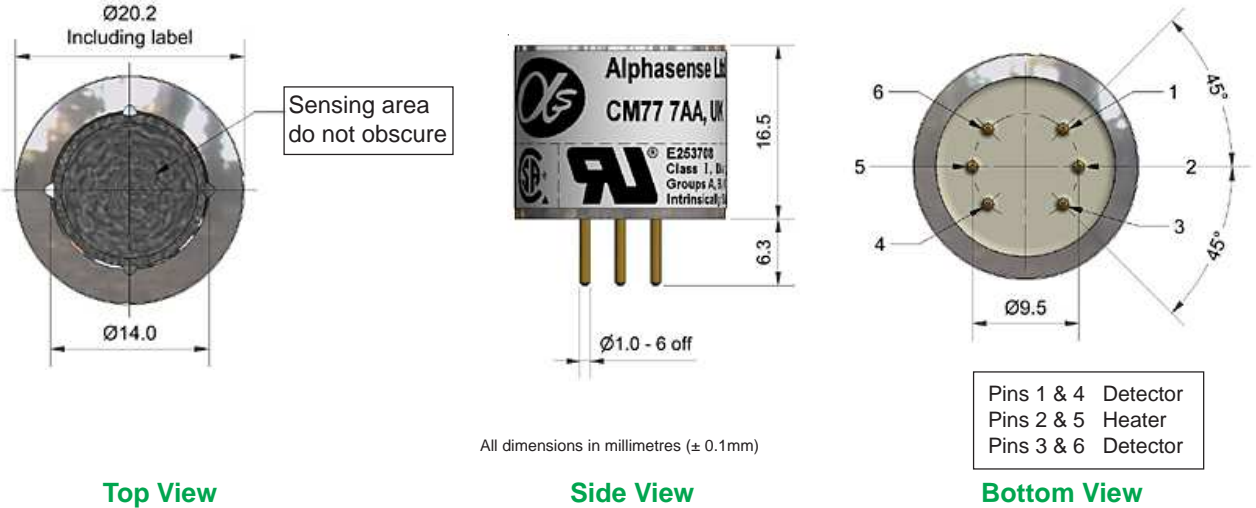

**Figure 5 Basic Measuring Circuit for TO-5 package**

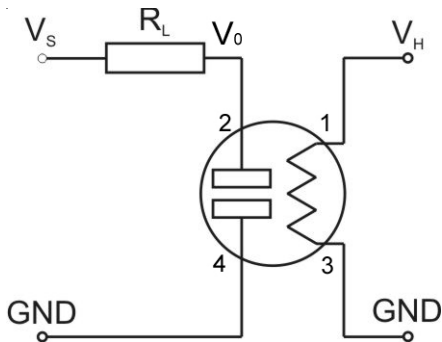

Pins on the measuring circuit correspond with the pin numbers in Figure 1 & 2

When the sensor is connected in this half Wheatstone bridge configuration,  $V_0$  increases as the sensing material resistance increases.

Heater Voltage ( $V_H$ )  $V_{H400} 2.7 \pm 0.2 \text{ V}; V_{H525} 3.7 \pm 0.3 \text{ V (DC)}$   
 Circuit Voltage ( $V_S$ ) Max. 1 VDC  
 Load Resistance ( $R_L$ )  $> 100 \text{ k}\Omega$

**Figure 6 Resistance/temperature for Alphasense Metal Oxide Gas Sensor heaters**

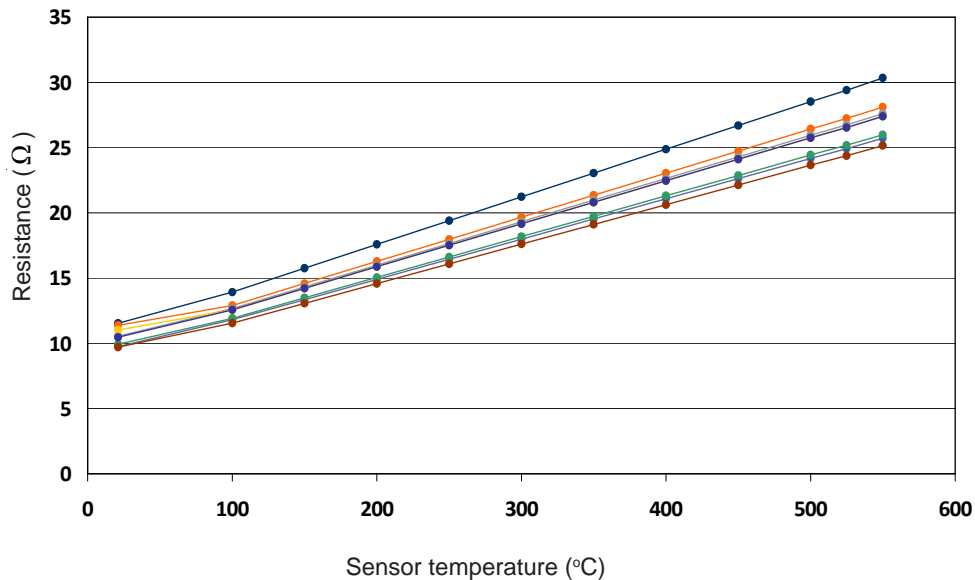

Sensing temperature ( $400^\circ\text{C}$ ) and reset temperature ( $525^\circ\text{C}$ ) variances should be allowed in your circuit



# p-Type Metal Oxide Sensor Overview



Technical Specification

## CERTIFICATION

Sira 07ATEX 1088X



II 2 G  
Ex d IIC T4  
-40°C to 55°C  
5V, 1.4 W

IECEX SIR07.0031X

Ex d IIC T4  
5Vdc, 1.25 W, T<sub>a</sub> -40° to 55°C

UL913 091007-E253708

Class I, II and III, Division 1  
10 V, 1.5 W, 10 µH

CSA 22.2 1906313

Class 4828 31

SPECIAL CONDITIONS FOR SAFE USE (denoted by X after the certificate number)

The non-metallic parts of the Flameproof Sensor Housings shall only be installed in enclosures that offer protection from mechanical impact damage and shall not be exposed to ultraviolet radiation.

The final installation of the Flameproof Sensor Housings shall ensure that any likely damage from dropping the complete device has been considered.

The Flameproof Sensor Housings shall only be connected to an electrical supply that is certified as compliant with IEC 60079-11 and limited to the following: Type A - 5 Vdc, 1.4 W



At the end of the product's life, do not dispose of any electronic sensor, component or instrument in the domestic waste, but contact the instrument manufacturer, Alphasense or its distributor for disposal instructions.

For further information on the performance of this sensor, on other sensors in the range or any other subject, please contact Alphasense Ltd. For Application Notes visit "[www.alphasense.com](http://www.alphasense.com)".

*In the interest of continued product improvement, we reserve the right to change design features and specifications without prior notification. The data contained in this document is for guidance only. Alphasense Ltd accepts no liability for any consequential losses, injury or damage resulting from the use of this document or the information contained within. (©ALPHASENSE LTD) Doc. Ref. MMO/JAN18*