



CO-AF Carbon Monoxide Sensor



PATENTED

Figure 1 CO-AF Schematic Diagram

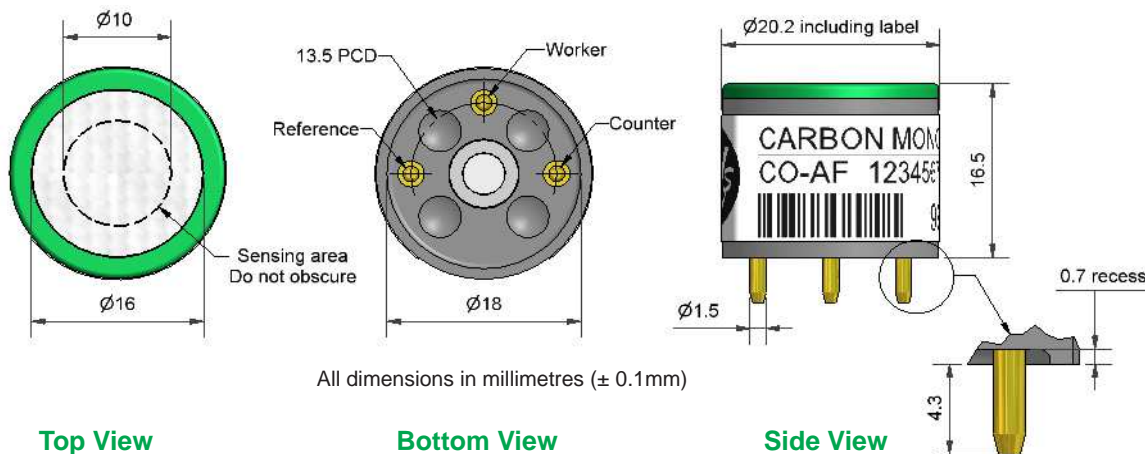

Technical Specification

| | | | |
|---|------------------------------|---|-----------------------------|
| PERFORMANCE | Sensitivity | nA/ppm in 400ppm CO | 55 to 90 |
| | Response time | t_{90} (s) from zero to 400ppm CO | < 25 |
| | Zero current | ppm equivalent in zero air | -5 to +4 |
| | Resolution | RMS noise (ppm equivalent) | < 0.5 |
| | Range | ppm CO limit of performance warranty | 5,000 |
| | Linearity | ppm error at full scale, linear at zero, 1000ppm CO | +15 to +25 |
| | Overgas limit | maximum ppm for stable response to gas pulse | 10,000 |
| LIFETIME | Zero drift | ppm equivalent change/year in lab air | < 0.2 |
| | Sensitivity drift | % change/year in lab air, monthly test | < 8 |
| | Operating life | months until 80% original signal (24 month warranted) | > 24 |
| ENVIRONMENTAL | Sensitivity @ -20°C | % (output @ -20°C/output @ 20°C) @ 400ppm CO | 63 to 88 |
| | Sensitivity @ 50°C | % (output @ 50°C/output @ 20°C) @ 400ppm CO | 102 to 115 |
| | Zero @ -20°C | ppm equivalent change from 20°C | < ± 3 |
| | Zero @ 50°C | ppm equivalent change from 20°C | < ± 8 |
| CROSS SENSITIVITY | Filter capacity | ppm-hours | H ₂ S 250,000 |
| | Filter capacity | ppm-hours | NO ₂ 600,000 |
| | Filter capacity | ppm-hours | NO 20,000 |
| | Filter capacity | ppm-hours | SO ₂ 300,000 |
| | H ₂ S sensitivity | % measured gas @ 20ppm | H ₂ S < 0.1 |
| | NO ₂ sensitivity | % measured gas @ 10ppm | NO ₂ < 0.1 |
| | Cl ₂ sensitivity | % measured gas @ 10ppm | Cl ₂ < 0.1 |
| | NO sensitivity | % measured gas @ 50ppm | NO < 5 |
| | SO ₂ sensitivity | % measured gas @ 20ppm | SO ₂ < 0.1 |
| | H ₂ sensitivity | % measured gas @ 400ppm | H ₂ at 20°C < 60 |
| C ₂ H ₄ sensitivity | % measured gas @ 400ppm | C ₂ H ₄ < 25 | |
| NH ₃ sensitivity | % measured gas @ 20ppm | NH ₃ < 0.1 | |
| KEY SPECIFICATIONS | Temperature range | °C | -30 to 50 |
| | Pressure range | kPa | 80 to 120 |
| | Humidity range | % rh continuous | 15 to 90 |
| | Storage period | months @ 3 to 20°C (stored in sealed pot) | 6 |
| | Load resistor | Ω (recommended) | 10 to 47 |
| | Weight | g | < 6 |



At the end of the product's life, do not dispose of any electronic sensor, component or instrument in the domestic waste, but contact the instrument manufacturer, Alphasense or its distributor for disposal instructions.

NOTE: all sensors are tested at ambient environmental conditions, with 10 ohm load resistor, unless otherwise stated. As applications of use are outside our control, the information provided is given without legal responsibility. Customers should test under their own conditions, to ensure that the sensors are suitable for their own requirements.



CO-AF Performance Data

Technical Specification

Figure 2 Sensitivity Temperature Dependence

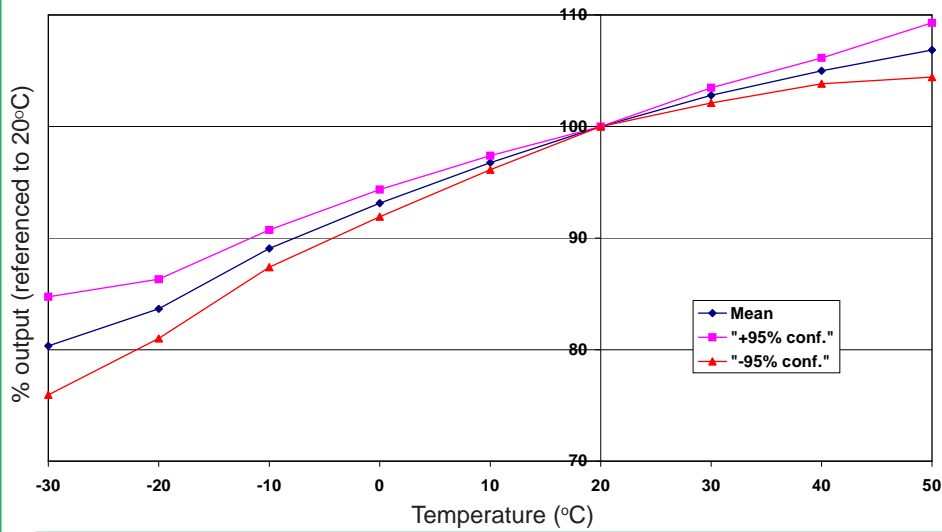

Figure 2 shows the variation in sensitivity caused by changes in temperature.

This data is taken from a typical batch of sensors. The mean and $\pm 95\%$ confidence intervals are shown.

Figure 3 Zero Temperature Dependence

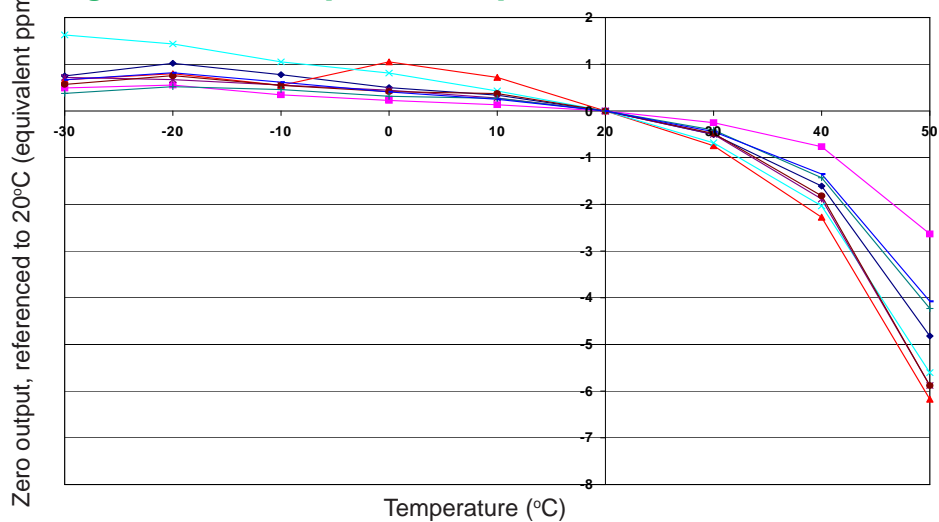

Figure 3 shows the variation in zero output caused by changes in temperature, expressed as ppm gas equivalent, referenced to zero at 20°C.

This data is taken from a typical batch of sensors.

Figure 4 Response to Exposure to 2% CO

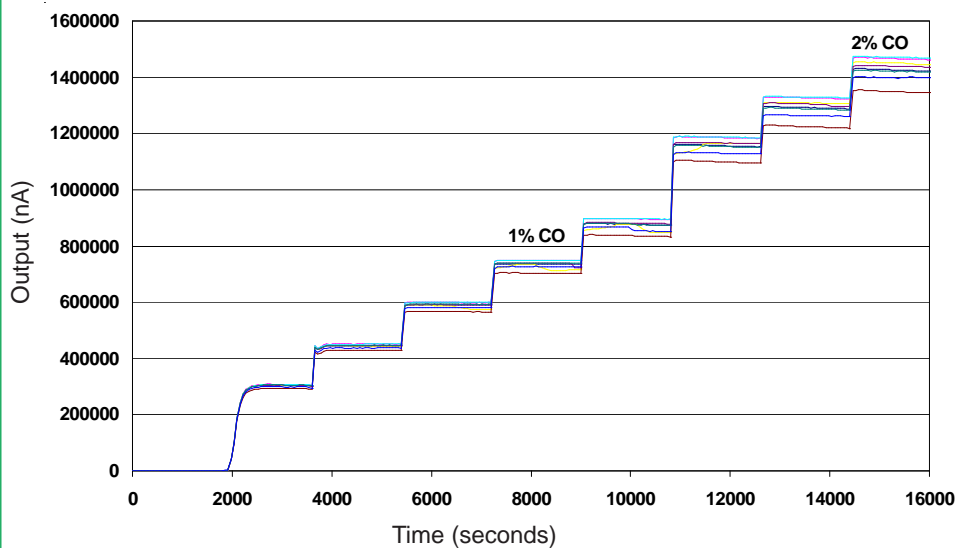

Figure 4 shows the excellent response to step changes in CO concentrations from zero to 2% CO by volume.

This data is taken from a typical batch of sensors.

For further information on the performance of this sensor, on other sensors in the range or any other subject, please contact Alphasense Ltd. For Application Notes visit "www.alphasense.com"

In the interest of continued product improvement, we reserve the right to change design features and specifications without prior notification. The data contained in this document is for guidance only. Alphasense Ltd accepts no liability for any consequential losses, injury or damage resulting from the use of this document or the information contained within (©ALPHASENSE LTD) Doc. Ref. COAF/SEPT17